

XTD-400DBL C-Band, Ku-Band Dual-Band Antenna Mount Amplifiers



- **325 Watts, C-Band
325 Watts, Ku-Band**
- **No Shelter Required**
- **Short Waveguide Run**
- **Power Factor Corrected**
- **High Efficiency Dual-Stage
TWTs**
- **Microprocessor M&C Interface**

The XTD-400DBL series are compact self-contained antenna mountable power amplifiers designed for low cost installation and long life. The XTD-400DBL series design eliminates the need for an amplifier shelter as well as a long waveguide run between the amplifier and the antenna feed horn; for example, an antenna mounted 350 Watt amplifier with its shorter waveguide run will often deliver EIRP comparable to a 600 Watt rack mounted HPA. RF filters, cooling, and monitoring & control systems are all self-contained within the HPA. These features provide high reliability, low maintenance costs, and low replacement costs.

The XTD-400DBL series incorporates high efficiency, dual-stage collector TWTs. Some of the benefits of this type of TWT are: reduced prime power consumption, lower internal operating temperatures, and reliability enhancement. These benefits are obtained for both the linear and saturated modes of operation. One of the features of the XTD-400DBL series is incorporation of power factor correction circuitry

that minimizes line current distortion and reduces the required volt-amps. The combination of power factor correction and high efficiency TWTs reduces input Volt-Amps by 45% when compared to equivalent amplifiers. A high frequency resonant conversion power supply is used that accepts a wide range of prime power (100 to 260 VAC). The automatic features of the power supply include quick recovery from prime power outages and multiple helix fault resets (three fault cycles).

A complete monitoring & control system is built into the unit. Ten status and fault monitors are provided for external monitoring.

The XTD-400DBL series can be configured for single thread, redundant, phase combined, or linearized operation.

A remote external controller is available to operate the HPA from a user selected location. Mounting brackets can be supplied to mount the HPA to most popular antennas.

BUY NOW

PERFORMANCE SPECIFICATIONS

Parameter	C-Band, XTD-400DBL	Ku-Band, XTD-400DBL
FREQUENCY RANGE	5.850 to 6.425 GHz	14.0 to 14.5 GHz
OUTPUT POWER		
Traveling Wave Tube	325 W	325 W
Amplifier Flange	290 W	290 W
GAIN		
Large Signal, min-max	64-71 dB	64-71 dB
Small Signal, minimum	69 dB	69 dB
Maximum SSG Variation Over:		
Any Narrow Band	1.0 dB 40 MHz	1.0 dB 40 MHz
Full Band	± 1.5 dB	± 1.5 dB/500 MHz
Slope, maximum	±0.04 dB/MHz	±0.04 dB/MHz
Stability, 24 Hr maximum	± 0.25 dB	± 0.25 dB
Stability, Temperature	± 1.0/1.5 dB maximum over temperature range at any frequency	
ATTENUATOR RANGE	Rated Power -10 dB	
SPECTRAL OCCUPANCY	-26 dBc @ 1.64 MHz offset from carrier @ rated power, QPSK, @ 1.64 Mb/s	-26 dBc @ 1.64 MHz offset from carrier @ rated power, QPSK, @ 1.64 Mb/s
HARMONIC OUTPUT, maximum	0 dBc @ 49 dBm	-12 dBc
AM/PM CONVERSION, maximum	2.5 deg/dB at 6 dB below rated power	
NOISE POWER, maximum		
Transmit Band	- 70 dBW/4 kHz	- 70 dBW/4 kHz
Receive Band	- 70 dBW/4 kHz 3.7 to 4.2 GHz	- 70 dBW/4 kHz 10.95 to 12.75 GHz
GROUP DELAY, maximum		
Bandwidth	Any 40 MHz	Any 80 MHz
Linear	0.01 nS/MHz	0.01 nS/MHz
Parabolic	0.005 nS/MHz ²	0.005 nS/MHz ²
Ripple	0.5 nS/Pk-Pk	0.5 nS/Pk-Pk
RESIDUAL AM NOISE, maximum	- 50 dBc to 10 kHz - 20 (1.5 + logf) dBc 10 to 500 kHz - 85 dBc above 500 kHz	
PHASE NOISE, maximum	10 dB below IESS phase noise profile AC fundamental -50 dBc Sum of all spurs -47 dBc	
VSWR		
Input, maximum	1.3:1	1.3:1
Output, maximum	2.2:1	2.2:1

PRIME POWER

100-260 VAC
47 to 63 Hz, single phase
2200 VA Maximum
0.95 Minimum Prime Power Factor

OPTIONS

Remote External Controller
Extended Frequency Coverage
1:1, 1:2, 1:N Redundancy
Variable Phase Power Combining
Integrated Linearizers



ENVIRONMENT

NONOPERATING TEMPERATURE RANGE	-50° C to + 70° C
OPERATING TEMPERATURE RANGE	-40° C to +50° C
HUMIDITY	Up to 100% Condensing
ALTITUDE	10,000 feet MSL maximum
SHOCK AND VIBRATION	Normal Transportation
COOLING	Forced Air

INTERFACE

TYPE	FUNCTION		
CONTROLS - LOCAL	HV ON/OFF/Fault Reset Power ON/OFF	PS ON/OFF	Local/Remote
CONTROLS - RS-485	RF Attenuation Fault Reset	HV ON/OFF	
MONITORS - LOCAL	Three-color LED indicating FTD, Standby, HV ON, and Fault Conditions		
MONITORS - RS-485	High Voltage ON TWT Temperature Heater Warm-up Time Delay (FTD) Summary fault	Helix Voltage RF Output Power Helix Current/Arc Fault High Voltage Fault	Helix Current Standby Helix Current Latched Fault Temperature Fault

XTD-400DBL Dual-Band High Power Amplifiers



Block Diagram

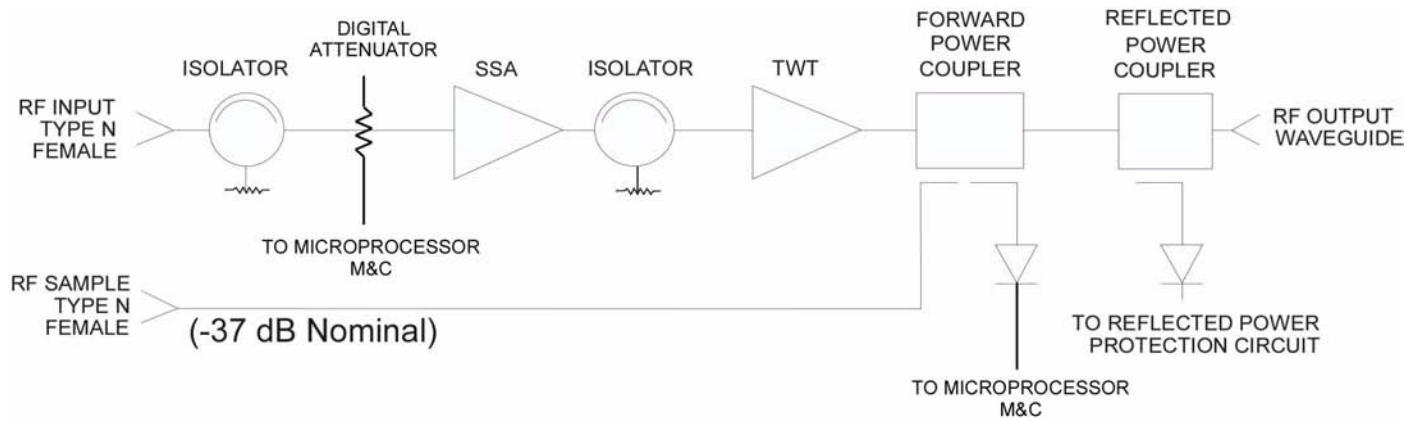

Outline Drawing

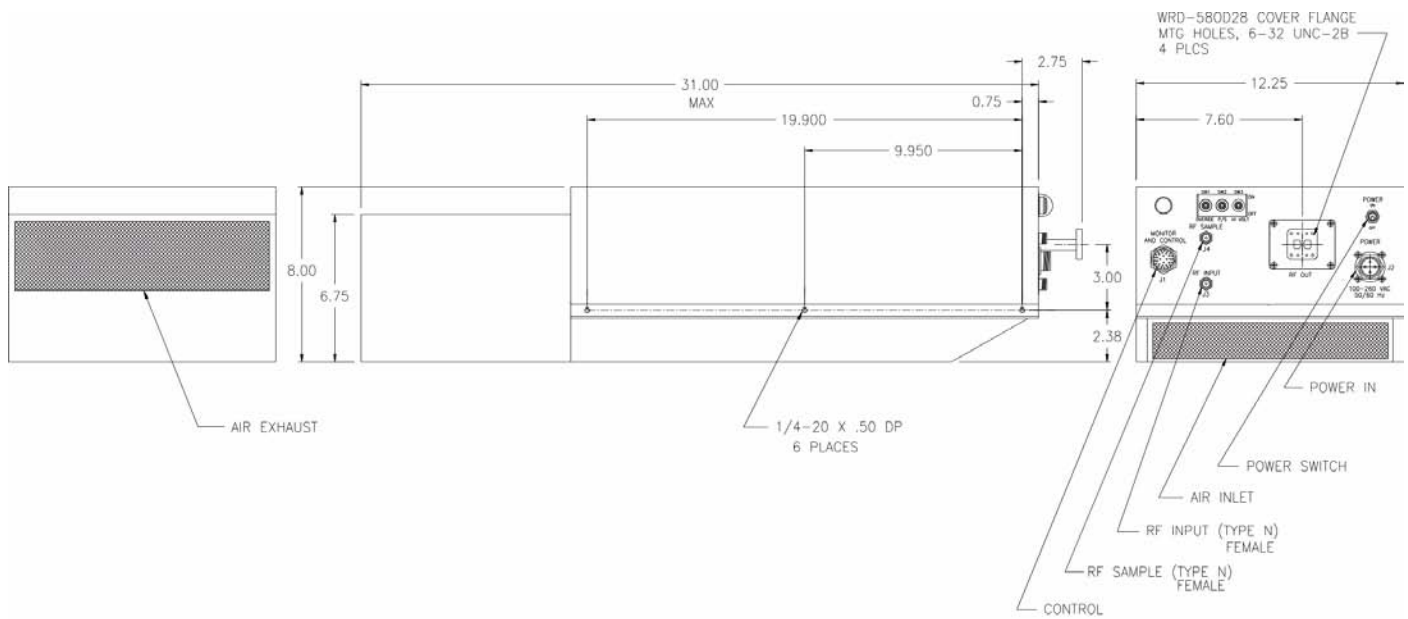

Typical Weight: 60 lbs (27.22 kg)



Document # 805-1124-001 05/02/2007
XTD-400DBL REV 3
© 2007
Note: Technical specifications are subject to change without notice. Please contact Xicom Technology before using this information for system design.



Post Office Box 1639
101 Eagle Road - Building #7
Avon, Colorado 81620 USA
970 748-3094 or tollfree 866 SATCOM1
Fax 970 748-3096
www.satcomresources.com