



4096-291
REVISION F
January 11, 2002

ASSEMBLY MANUAL

1.8 METER SERIES 1183 Rx/O Az/EI MOUNT ANTENNA SYSTEM

PRODELIN CORPORATION

1.8 METER SERIES 1183 Rx/O Az/EI MOUNT ANTENNA SYSTEM

F	Revised Address	1/11/01	
E	Updated Manual	08/03/98	PGW
D	Revised Canister assembly per ECN 1837	7/14/98	PGW
C	Revised antenna asm parts list, lt. 8&9 were qty of 2, Updated manual	06/10/97	P.G.W.
B	Added revision page & changed P/N for item #7	03/31/95	R.F.
~	Original Release	11/20/92	R.F.
REV.	DESCRIPTION	DATE	APPROVED

1.8M SERIES 1183 ANTENNA SYSTEM**TABLE OF CONTENTS**

<u>SECTION</u>	<u>TITLE</u>
I	GENERAL INFORMATION
1.0	Introduction
1.1	Unpacking And Inspection
1.2	Freight Damage
1.3	Missing Or Damaged Material
1.4	Suggested Tool List
1.5	Mechanical Alignment Tools
1.6	Site Selection
1.7	Suggested Mast & Foundation
II	ANTENNA SYSTEM
2.0	Antenna Assembly
III	FEED SUPPORT
3.0	Feed Support Assembly
IV	ANTENNA POINTING
4.0	Alignment To Satellite
V	MAINTENANCE
5.0	Maintenance Overview
5.1	Periodic Inspection
5.2	Reflector
5.3	Mount And Reflector Support
5.4	Feed System

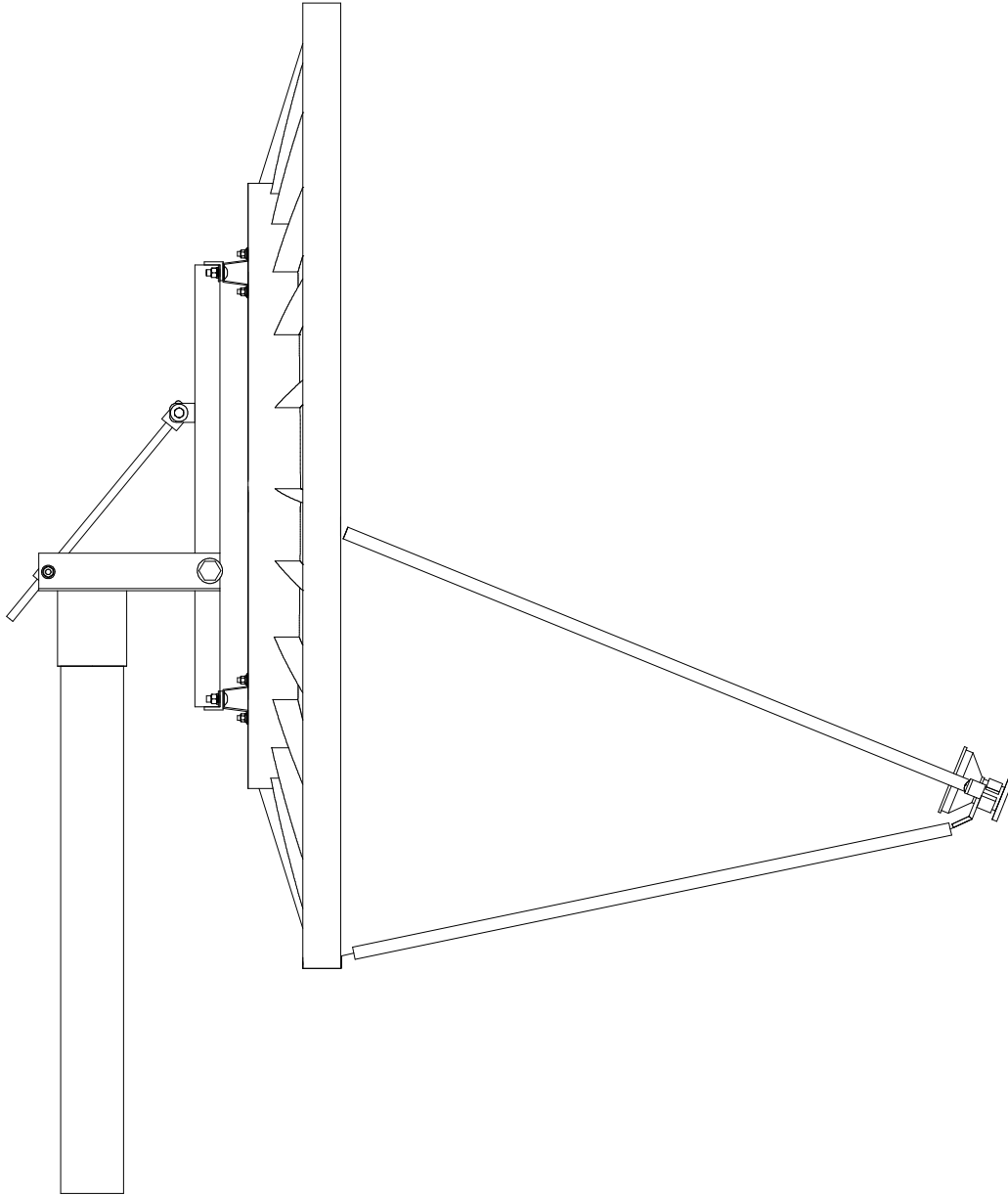

SECTION I **GENERAL INFORMATION****1.0** **INTRODUCTION**

This manual describes the assembly and installation of Prodelin's 1.8M Rx/O antenna system with an Az/EI mount (series number 1183). The Prodelin 1.8M is a rugged, reliable antenna system, which will operate with high efficiency and at the same time successfully withstand the effects of the environment. The basic 1.8 meter Rx/O antenna consists of an offset reflector, reflector support, feed support structure and Az/EI positioner.

These instructions are listed by sections that cover all areas of assembly and installation. Additional sections are included in the manual to provide information on antenna alignment to the satellite and maintenance.

1.1 **UNPACKING AND INSPECTION**

The antenna containers should be unpacked and inspected at the earliest date to ensure that all material has been received and is in good condition. A complete packing list for each major component is supplied.

1.2 **FRIEGHT DAMAGE**

Any damage to materials while in transit should be immediately directed to the freight carrier. He will instruct you on matters regarding any freight damage claims.

1.3 **MATERIAL - MISSING OR DAMAGED**

Any questions regarding missing or damaged materials that is not due to the freight carrier should be directed to Prodelin's Customer Service Department at:

PRODELIN CORPORATION

1.4 **SUGGESTED TOOL LIST**

The following tools are suggested for the antenna installation.

HARDWARE SIZE	SAE WRENCH SIZE	METRIC WRENCH SIZE	MAXIMUM REC. TORQUE
1/4" BOLT	7/16"	11mm	49 in-lbs
5/16" BOLT	1/2"	13 mm	12 ft-lbs
3/8" BOLT	9/16"	14 mm	20 ft-lbs
1/2" BOLT	3/4"	20 mm	45 ft-lbs
5/8" NUT	15/16"	24 mm	70 ft-lbs
1" BOLT	1-1/2"	38 mm	220 ft-lbs

1.5 MECHANICAL ALIGNMENT TOOLS

The following tools are suggested for the initial alignment to the satellite.

- 1) COMPASS
- 2) INCLINOMETER
- 3) 10" CRESCENT WRENCH
- 4) SCREWDRIVER, STANDARD BLADE

1.6 SITE SELECTION

In order to achieve maximum performance of your antenna system, it is important to select the correct location for the antenna. The following guidelines should be observed when selecting a site for the installation.

1. The line of site to the satellite should be clear of any obstructions, such as trees or buildings.
2. The site should be relatively flat and level for ease of installation and access to the antenna.
3. The site should be checked for underground obstruction, such as buried cables or pipes.
4. All local building codes should be adhered to (i.e. grounding, foundation requirements, zoning rules, setbacks, etc.).

1.7 SUGGESTED MAST & FOUNDATION

The required interface from the foundation to the mount is 3.5" schedule 40 pipe (4.0" or 10.16 cm O.D.). A suggested in-ground foundation is shown in Figure 1.

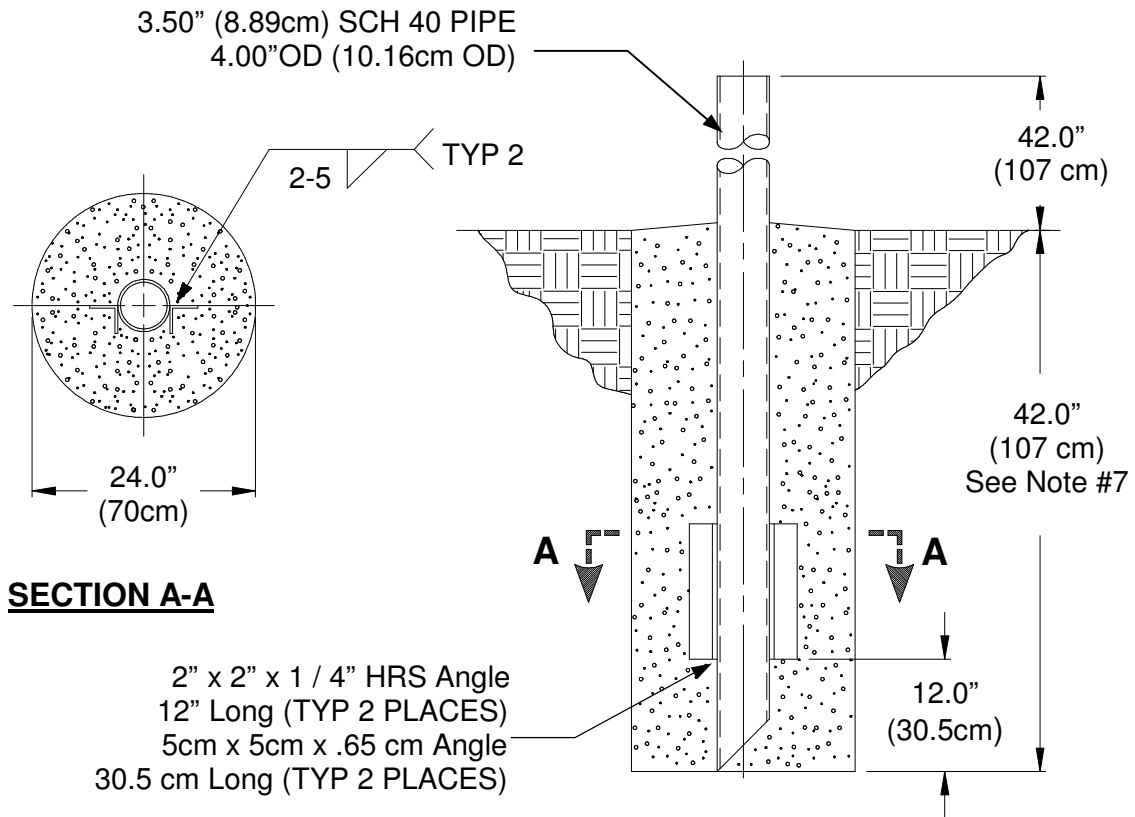

FIGURE 1.

NOTES:

1. 2 x 2 x 1/4 HRS Angle and schedule 40 pipe should conform with ASTM A36 and ASTM A53 Type E and S Grade B.
2. All concrete should conform to building code standards and have a minimum compressive strength of 3000 PSI at 28 days. (Per ACI-318-77)
3. Soil bearing capacity should be no less than 2000 PSF.
4. Concrete should be poured against undisturbed soil.
5. Allow concrete 24 hours set time before installation of antenna.
6. The antenna should be properly grounded to meet applicable local codes.
7. Minimum depth as shown or extend to local frost line.

(PRODELIN CORPORATION DOES NOT REPRESENT OR WARRANT THAT ANY PARTICULAR DESIGN OR SIZE OF FOUNDATION IS APPROPRIATE FOR ANY LOCALITY OR EARTH STATION INSTALLATION.)

SECTION II

ANTENNA ASSEMBLY

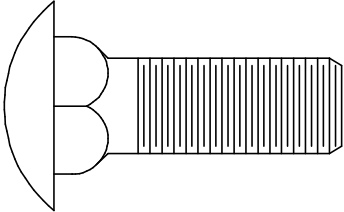
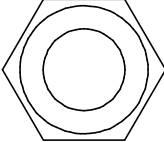
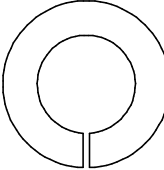
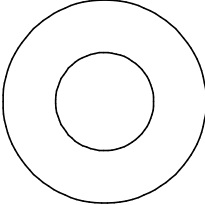
PARTS LIST - 1.8M ANTENNA ASSEMBLY			
ITEM	PART NO.	DESCRIPTION	QTY
1	0179-191	1.8M REFLECTOR	1
2	0181-452	CANISTER & POSITIONER ASSEMBLY	1
3	0211-417	REFLECTOR CROSS ARMS	2
4	8043-014	1 / 2" x 1.50" CARRIAGE BOLT	4
			
5	8104-007	1 / 2" HEX NUT	4
			
6	8202-043	1 / 2" LOCK WASHER	4
			
7	8201-043	1 / 2" WASHER	4
			

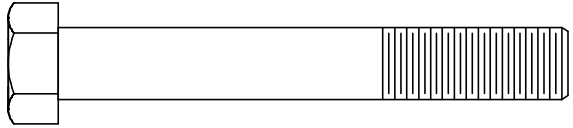
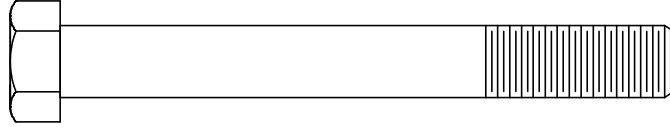
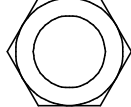
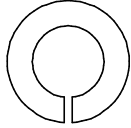
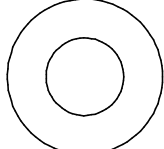
PARTS LIST - CONTINUED			
ITEM	PART NO.	DESCRIPTION	QTY
8	8032-036	3 / 8" x 4.5" HEX BOLT 	4
9	8032-040	3 / 8" x 5.0" HEX BOLT 	4
10	8102-007	3 / 8" HEX NUT 	8
11	8202-042	3 / 8" LOCK WASHER 	8
12	8201-042	3 / 8" WASHER 	16

CAUTION: During the assembly procedure, the sequence of instructions must be followed. DO NOT TIGHTEN ANY HARDWARE UNTIL INSTRUCTED.

2.0 ANTENNA ASSEMBLY

STEP 1:

Loosen the six 1/2 set screws on the canister (item 2) and slip the canister /positioner assembly onto the mast pipe, orient toward the satellite, and snug the set screws.

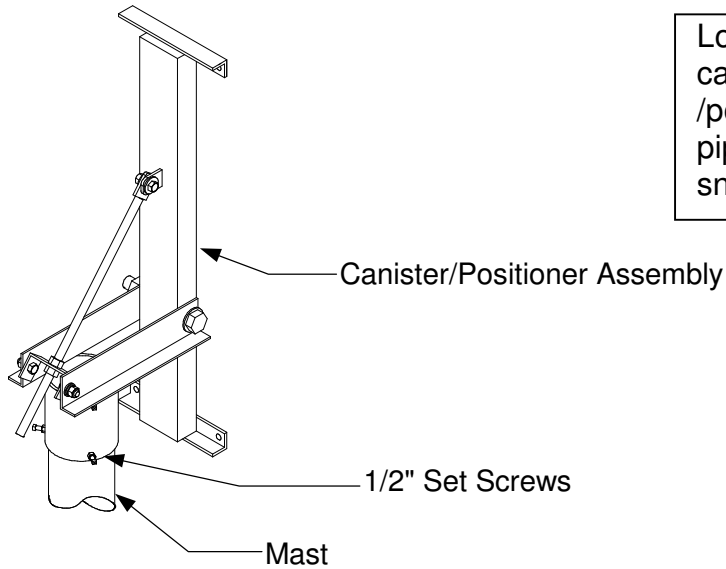

STEP 2:

Attach reflector cross arms (item 3) to the reflector support tube with 1 / 2" hardware (items: 4,5,6,7).

Note the orientation of reflector mounting holes, the inner most holes on the cross arm flanges will be to the top and the bottom of the reflector.

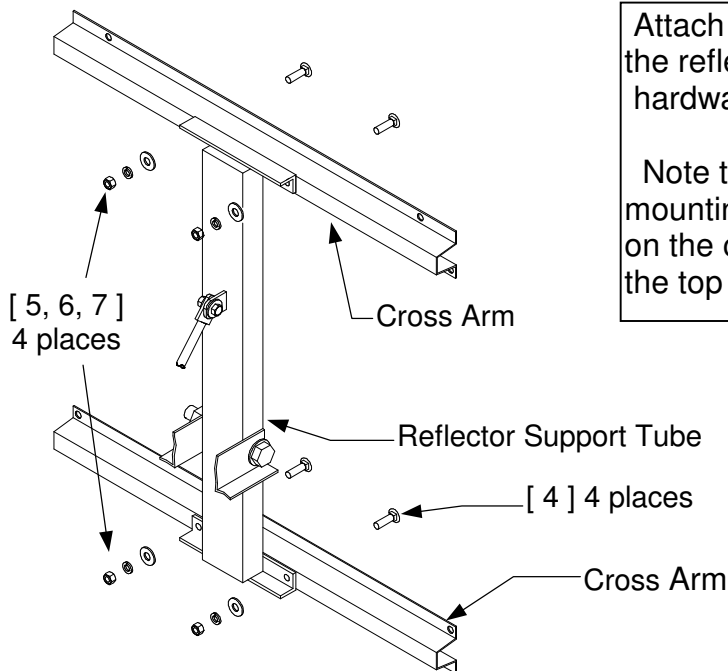

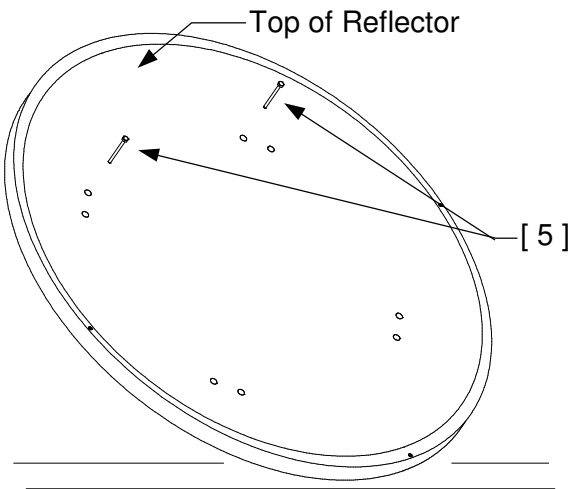

STEP 3:

Locate the top of the reflector and insert (2) 5" bolts (item 9) thru top two inner most holes on face of reflector as shown.

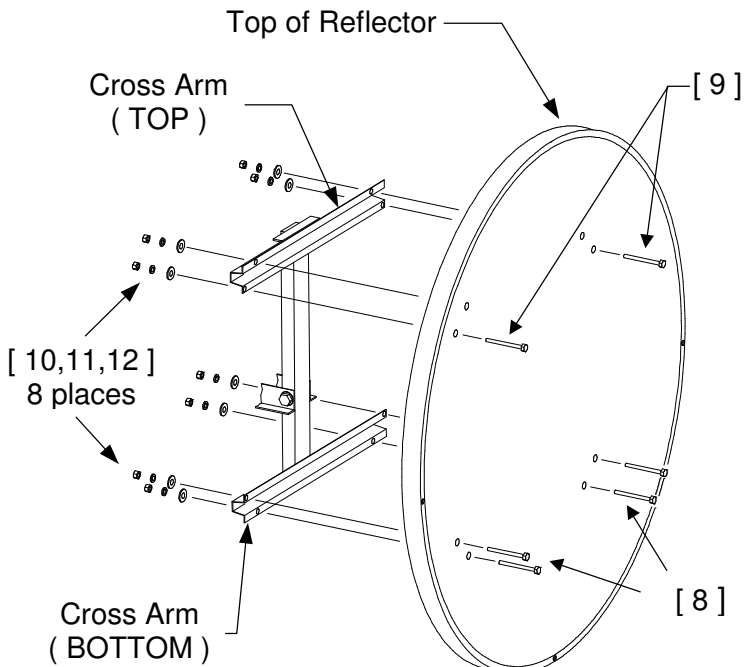



STEP 4:

- A). With a person on each side of the reflector, lift the reflector up.
- B). Position the reflector so that the (2) bolts (step 3) pass thru the two inner holes in the top cross arm.
- C). Loosely attach 3/8" hardware (items,10,11,12). **Note:** the reflector is fully supported at this time.
- D). Insert the (2) remaining 5" bolts (item 9) thru the remaining two holes on top of reflector.
- E). Insert the (4) 4.5" bolts (item 8) thru the four bottom holes in reflector.
- F). Secure with (items 10, 11, 12).
- G). Using the torque specifications on page 6, tighten all reflector and mount hardware.

SECTION III FEED SUPPORT ASSEMBLY

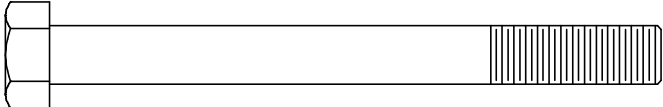
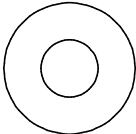
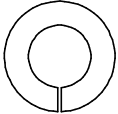
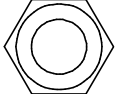
These instructions are intended as a general reference for feed support assembly. If your antenna system has specific feed or feed support installation instructions, please refer to them at this time.

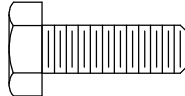
PARTS LIST - 1.8M FEED SUPPORT			
ITEM NO.	PART NO.	DESCRIPTION	QTY
1	0176-169	Feed Rod - Right Hand	1
2	0176-170	Feed Rod - Left Hand	1
3	0176-171	Feed Rod - Bottom	1
4	4080-059	Feed Bracket	1
5	4080-060	Feed Clamp	1
6	VARIABLES	50 Degree Feed Horn	1
7	8031-030	5 / 16" x 3.75" Bolt 	3
8	8201-041	5 / 16" Flatwasher 	6
9	8202-041	5 / 16" Lock Washer 	3
10	8101-009	5 / 16" Hex Nut 	3

PARTS LIST - CONTINUED			
ITEM	PART NO.	DESCRIPTION	QTY
11	8030-006	1/4" x .75" Hex Bolt 	5
12	8202-040	1/4" Lockwasher 	5
13	8102-007	1/4" Hex Nut 	5

CAUTION: During the assembly procedure, the sequence of instructions must be followed. ***Do Not Tighten Any Hardware Until Instructed.*** Refer to the feed support parts list and the steps shown below.

3.0 FEED SUPORT ASSEMBLY

STEP 1:

Attach right and left feed rods to the reflector with (items 7, 9,10) and with (2) of (item 8). Do not tighten See Figure 2 and Detail A.

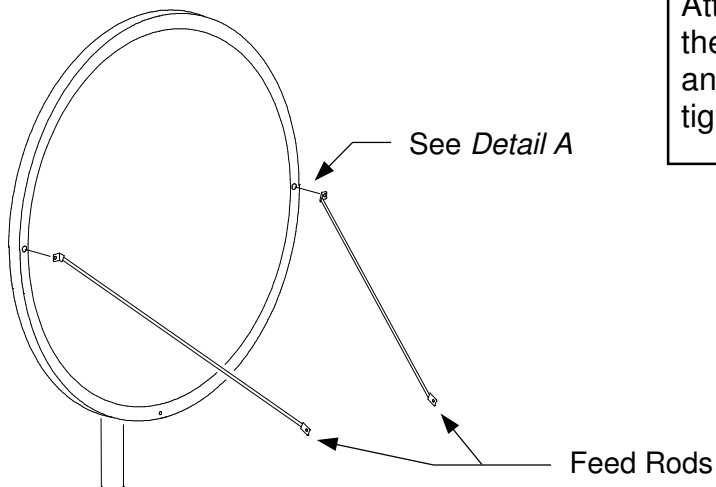

STEP 2:

Attach the bottom feed rod (item 3) to the bottom of the reflector with (items 7,9,10). and with (2) of (item 8). Do not tighten. See Detail B.

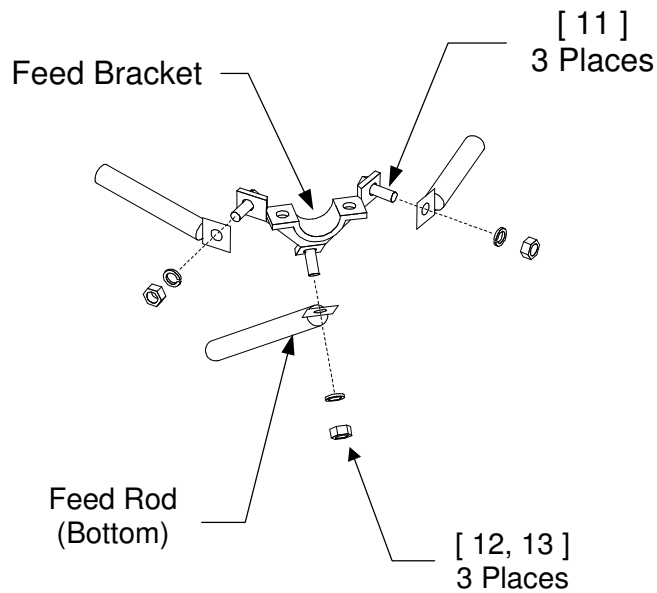
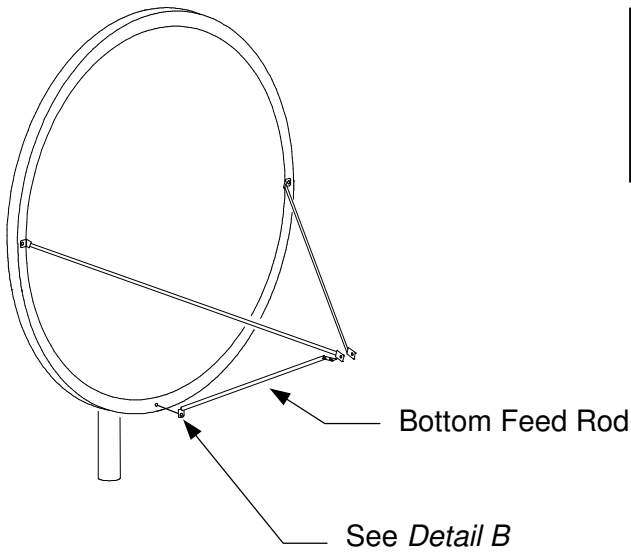

STEP 3:

Attach the feed bracket (item 4) to the ends of the three feed rods using 1/4" hardware (items 11, 12, 13). Note that the bolts should be inserted from inside the feed bracket, then through the feed rod ends. Securely tighten the six feed rod bolts at this time.

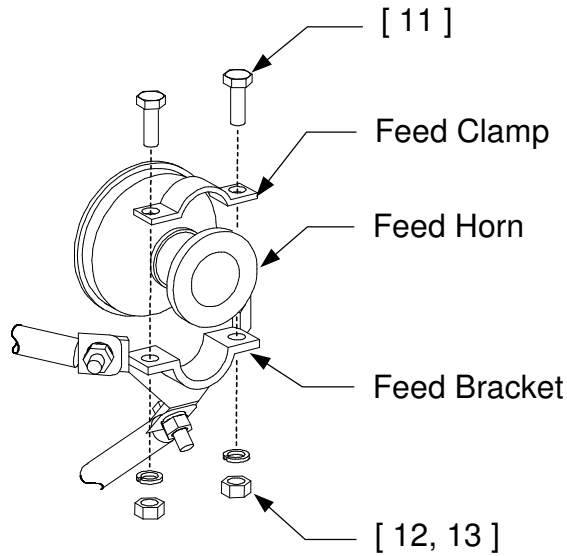

STEP 4:

- A) Assemble the feed horn (item 6) to the LNB (single pole) using the screws provided with the LNB or to the OMT (dual pole) using the o-ring and screws provided by Prodelin.
- B) Place the feed assembly into the saddle of the feed bracket (item 4) as shown, making sure that the shoulder of the feed horn in against the face of the bracket.
- C) Secure all in place with the feed clamp (item 5) and 1/4" hardware (items 11,12,13). Tighten securely.

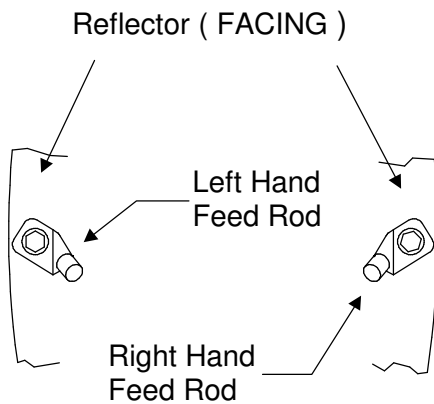
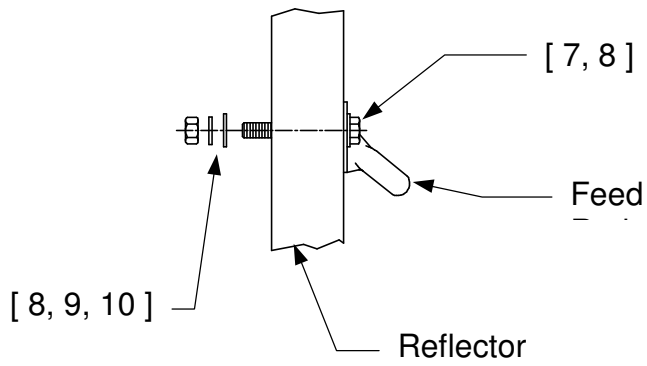
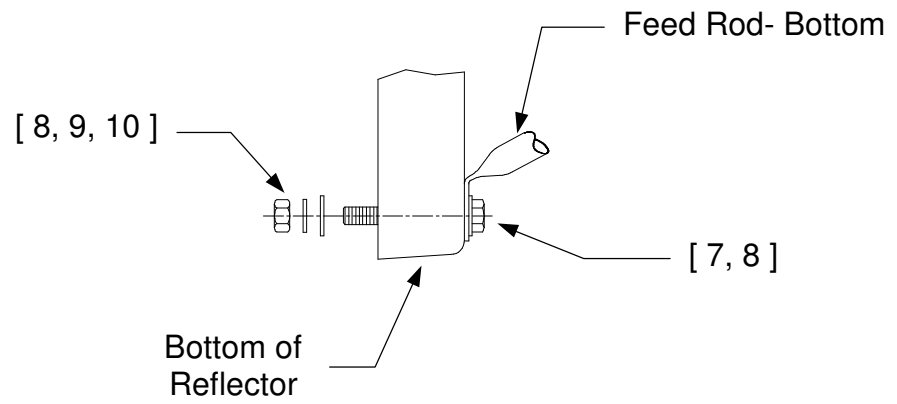

FIGURE 2

DETAIL A



DETAIL B



SECTION IV **ANTENNA POINTING****4.0** **ALIGNMENT TO SATELLITE**

The 1.8 meter offset reflector contains a 22.3° elevation offset look angle. Therefore, when the reflector aperture is perpendicular to the ground, the antenna is actually looking 22.3° in elevation. The lower back rib on the reflector is a Sight Reference Rib and can be used to read the correct elevation look angle.

- 1) Aligning to primary satellite: Place the inclinometer on the sight reference rib as shown in figure 3. This surface compensates for the 22.3° offset in the reflector, therefore a direct reading can be taken.
- 2) Raise or lower the antenna to find the desired elevation by turning the 5/8" nuts located on the elevation channel. Position the top nut so that it will not interfere with adjustment. Turn the bottom nut clockwise to increase elevation and counterclockwise to decrease elevation.
- 3) After the correct elevation angle is set, rotate the antenna in azimuth by loosening the six 1/2" set screws located on the canister and rotating the reflector assembly about the mast pipe until the correct signal is found.
- 4) Peak the antenna signal by fine adjustments made in both azimuth and elevation.
- 5) Tighten the four (6) 1/2" set screws in the canister.
- 6) Tighten all 5/8" hardware on the elevation adjustment rod and the reflector support tube.

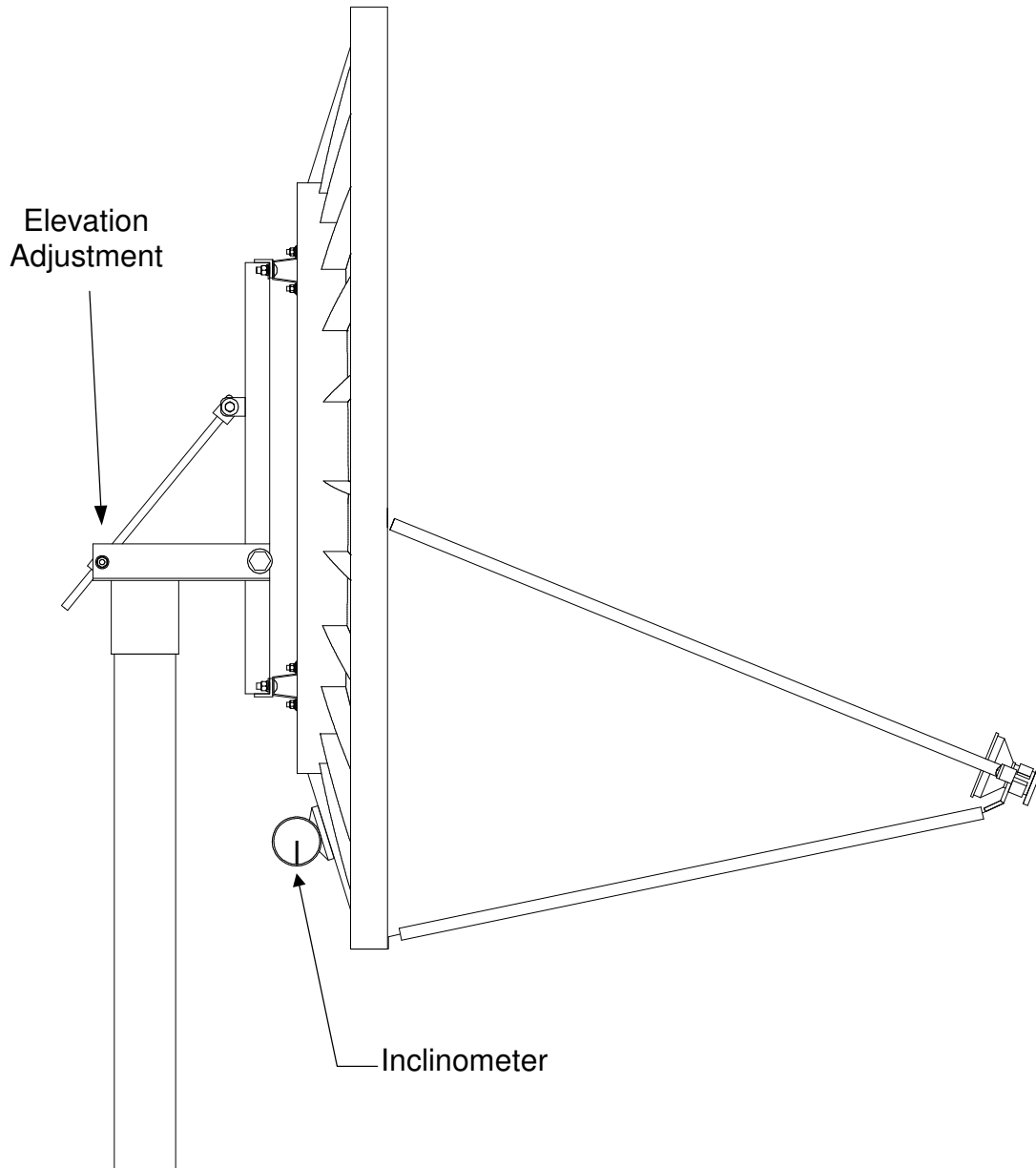

FIGURE 3

SECTION V **MAINTENANCE****5.0** **MAINTANANCE OVERVIEW**

After installation, the antenna requires only periodic inspection. It is anticipated that maintenance, if required, will be minimal and easily handled by a local or in-house maintenance staff. The materials used in the construction of this Earth Station Antenna virtually eliminate any maintenance repairs.

5.1 **PERIODIC INSPECTION**

It is suggested that a periodic inspection be performed at least every six months.

NOTE: After any very severe weather conditions, inspection of the antenna should be performed to determine if foreign objects have caused damage or if survival specifications have been exceeded.

This inspection should include the following:

- 1) Check all bolting locations - all bolts should be tight.
- 2) Check all structural members - repair or replace if damaged.
- 3) Check the foundation anchor bolts - they must be secure and with no failure signs in foundation.
- 4) Check for corrosion - on the reflector structure and mount.

5.2 **REFLECTOR**

Prodelin's reflector does not require any maintenance. The composite construction of the reflector is virtually impervious to any damages that could be caused by weather or other atmospheric conditions.

It is only necessary to inspect for any physical damage done by vandalism or very severe weather conditions.

Should any damage be detected to a portion of the reflector, contact the Customer Service Department at Prodelin for recommendations involving reflector repair.

5.3 **MOUNT AND REFLECTOR SUPPORT STRUCTURE**

The mount and reflector support structure supplied with this antenna is of steel construction and has a hot-dipped galvanized finish.

If inspection shows any signs of structural failure, the mount members that are damaged should be repaired or replaced.

Corrosion: Any corrosion on steel members may be repaired with a cold, zinc-rich galvanizing paint.

5.4 FEED SYSTEM

The feed support system should be inspected to insure that all hardware is secure. The feed/radio mounting bolts should be tight.

The feed horn window should be inspected to insure that it is intact so that no moisture can collect inside the feed horn. Replace if damaged.