



A TriPoint Global Company

4096-393

**August 21, 1997
Revision D**

ASSEMBLY MANUAL

**1.2M Ku-BAND Rx/Tx
SERIES 1134
ANTENNA SYSTEM**

PRODELIN CORPORATION

**1.2M Ku-BAND Rx/Tx
SERIES 1134 ANTENNA SYSTEM**

D	Revised per ECN2246	082197	PGW
C	Updated	3/18/97	PGW
B	Revised for back structure modification	9/16/96	PGW
A	Revise pgs. 5,7,8; Step 6, pg. 13. Figure 1 and 3 for clarity.	5/1/96	R Frye
-	ORIGINAL RELEASE	01/10/95	R Frye
REV.	DESCRIPTION	DATE	APPROVED

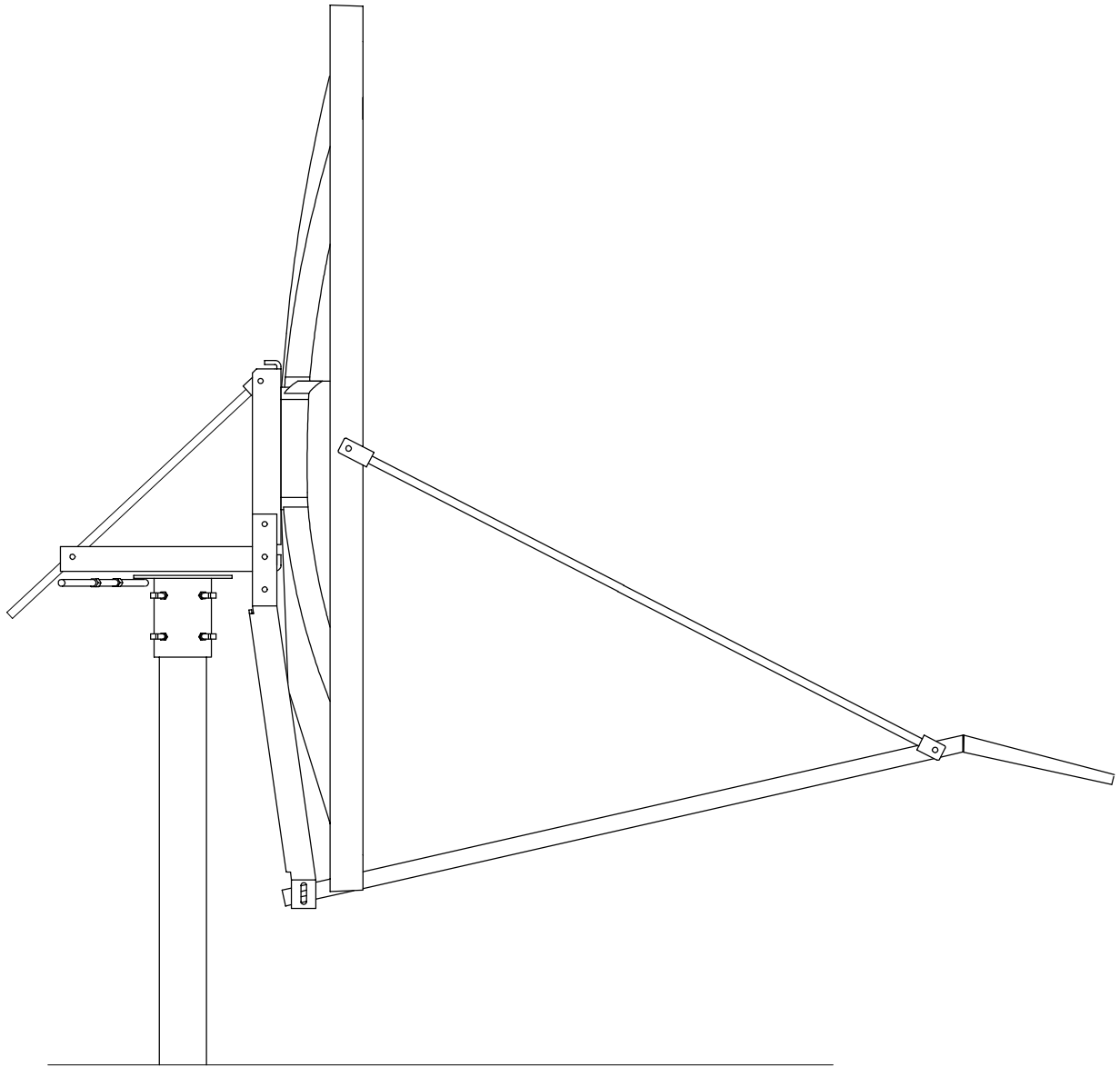

TABLE OF CONTENTS

<u>SECTION</u>	<u>TITLE</u>
I	INTRODUCTION
1.0	GENERAL INFORMATION
1.1	UNPACKING & INSPECTION
1.2	FREIGHT DAMAGE
1.3	MATERIAL MISSING OR DAMAGED
1.4	MECHANICAL INSTALLATION TOOLS
1.5	FOUNDATION INTERFACE
II	ANTENNA SYSTEM ASSEMBLY
2.0	ANTENNA ASSEMBLY
2.1	FEED ASSEMBLY
III	SATELLITE ALIGNMENT
3.0	ANTENNA POINTING
IV	MAINTENANCE
4.0	MAINTENANCE OVERVIEW
4.1	REFLECTOR
4.2	MOUNT & REFLECTOR SUPPORT
4.3	FEED & FEED SUPPORT

SECTION I INTRODUCTION

1.0 GENERAL INFORMATION

This manual describes the assembly and installation of Prodelin's 1.2 meter antenna system. The Prodelin 1.2 meter is a rugged and reliable mount which will operate in the Ku-Band frequency with high efficiency and at the same time successfully withstand the effects of the environment.

These instructions are listed by sections that cover all areas of assembly and installation. Additional sections are included in the manual to provide information on antenna alignment to the satellite and maintenance.

1.1 UNPACKING AND INSPECTION

The system containers should be unpacked and inspected at the earliest date to insure that all material has been received and is in good condition. A complete packing list for each major component is supplied.

1.2 FREIGHT DAMAGE

Any damage to materials while in transit should be immediately directed to the freight carrier. He will instruct you on matters regarding any freight damage claims.

1.3 MATERIAL - MISSING OR DAMAGED

Any questions regarding missing or damaged materials that is not due to the freight carrier should be directed to Prodelin's Customer Service Department at:

PRODELIN CORPORATION

1.4 MECHANICAL INSTALLATION TOOLS

The hardware supplied with this antenna system is U.S. SAE standard size and requires SAE wrench sizes. However, the sizes have been chosen to allow use with compatibly sized metric wrenches as shown in the table below.

HARDWARE SIZE	SAE WRENCH SIZE	METRIC WRENCH SIZE	MAXIMUM REC. TORQUE
5/16" Bolt	1/2"	13 mm	12 ft-lbs (1.66 kg-m)
1/2" Bolt	3/4"	20 mm	45 ft-lbs (6.20 kg-m)
27/64" Screw	1/2"	13 mm	Snug
5/8" Bolt	15/16"	24 mm	85 ft-lbs (11.7 kg-m)

Also recommended for installation:

Inclinometer
Compass
Adjustable Wrench

1.5 FOUNDATION INTERFACE

The required interface from the foundation to the mount is 2-1/2" schedule 40 pipe (2.88" or 7.3 cm O.D.). A suggested in-ground foundation is shown in Figure 1.

Also available from Prodelin, as options, are a kingpost pedestal mount and a non penetrating mast mount.

SUGGESTED IN-GROUND FOUNDATION

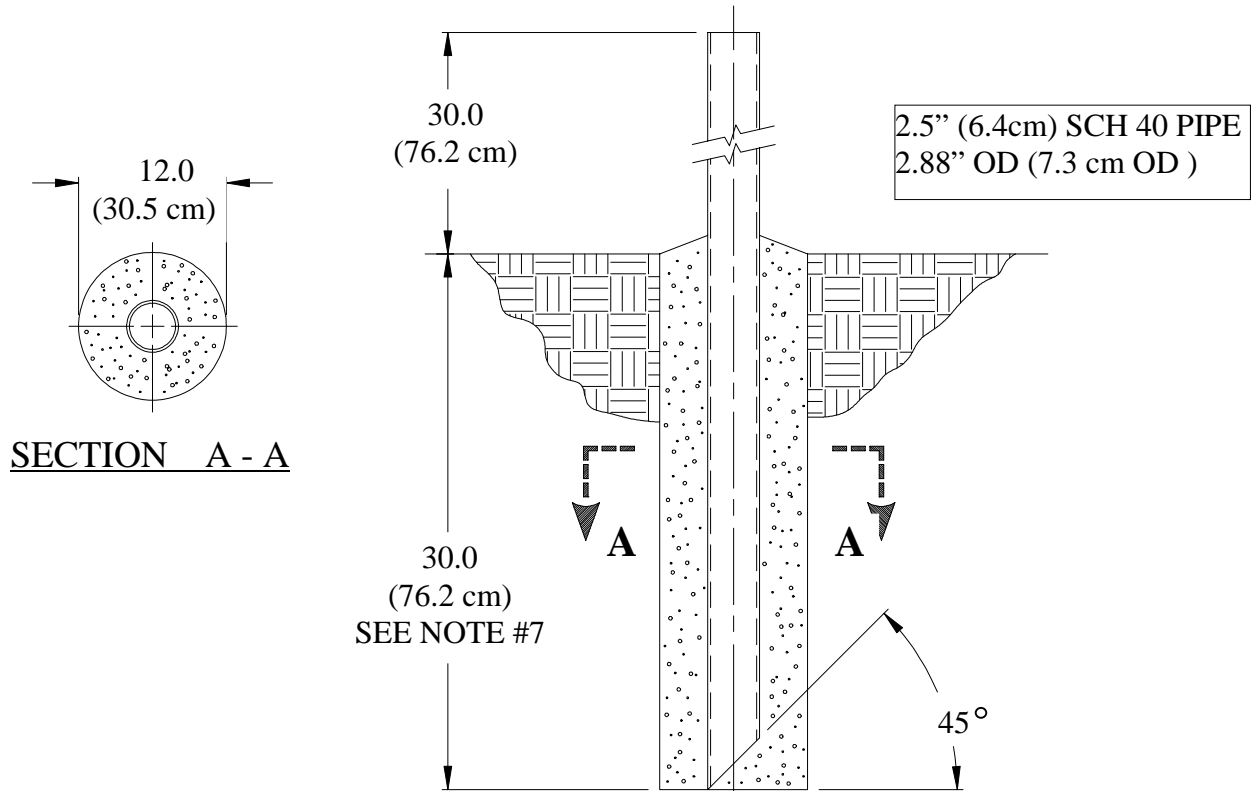

NOTES:

1. 2 1/2" schedule 40 pipe should conform with ASTM A53.
2. All concrete should conform to building code standards and have a minimum compressive strength of 3000 PSI at 28 days. (Per ACI-318-77)
3. Soil bearing capacity should be no less than 2000 PSF.
4. Concrete should be poured against undisturbed soil.
5. Allow concrete 24 hours set time before installation of antenna.
6. The antenna should be properly grounded to meet applicable local codes.
7. Minimum depth as shown or extend to local frost line.
8. Foundation meets the design requirements as set forth by the uniform building code. (1982 edition)

(PRODELIN CORPORATION DOES NOT REPRESENT OR WARRANT THAT ANY PARTICULAR DESIGN OR SIZE OF FOUNDATION IS APPROPRIATE FOR ANY LOCALITY OR EARTH STATION INSTALLATION.)

Figure 1.

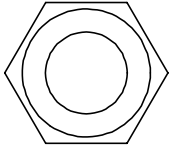
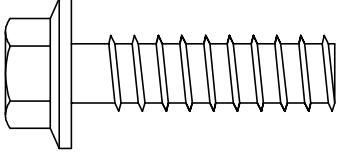
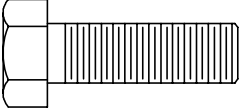
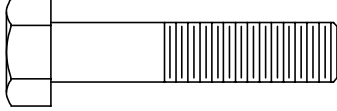
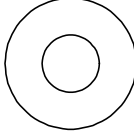
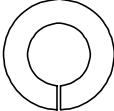
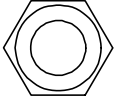
PARTS LIST - 1.2M ANTENNA ASSEMBLY			
ITEM NO.	PART NO.	DESCRIPTION	QTY
1	0181-585	Canister Assembly	1
2	0181-584	Mount Assembly	1
3	VARIABLES	1.2M Reflector	1
4	0490-203	Elevation Rod	1
5	8104-007	1 / 2 - 13 Hex Nut	2
			
6	8319-006	Hi - Lo Screw	4
			
7	8031-008	5 / 16" x 1.00" Bolt	2
			
8	8031-012	5 / 16" x 1.50" Bolt	1
			
9	8201-041	5 / 16" Flat Washer	4
			
10	8202-041	5 / 16" Lock Washer	3
			
11	8101-009	5 / 16" Hex Nut	3
			

SECTION II

ANTENNA ASSEMBLY

CAUTION: During the assembly procedure, the sequence of instructions must be followed. ***Do Not Tighten Any Hardware Until Instructed*** . Refer to the antenna assembly parts list and the steps shown below.

2.0 ANTENNA ASSEMBLY

STEP 1:

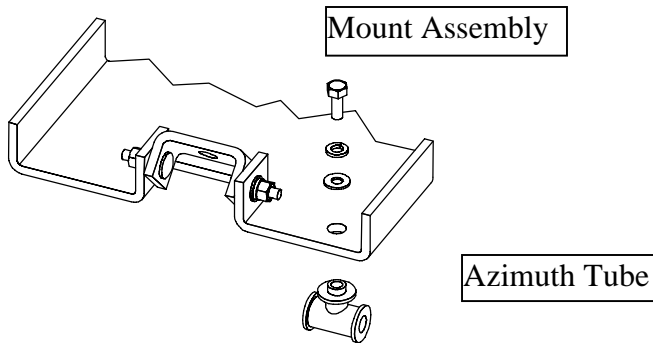

- A). Remove azimuth tube from mount assembly.
- B). Set azimuth tube and hardware aside.

STEP 2:

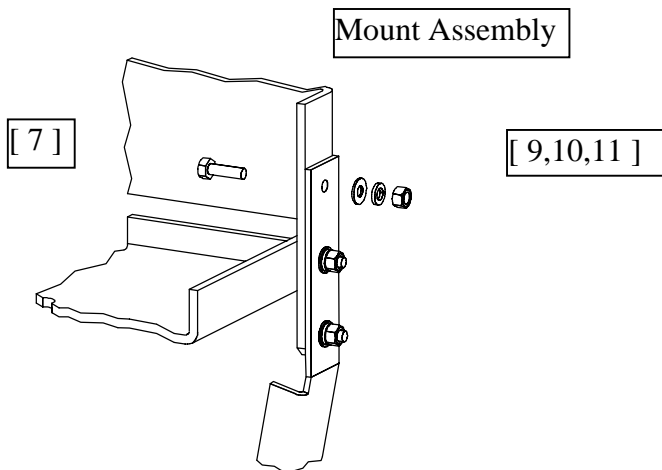

- A). Insert 5 / 16” hardware (items: 7,9,10, 11) thru hole on mount assembly as shown. Repeat on opposite side.

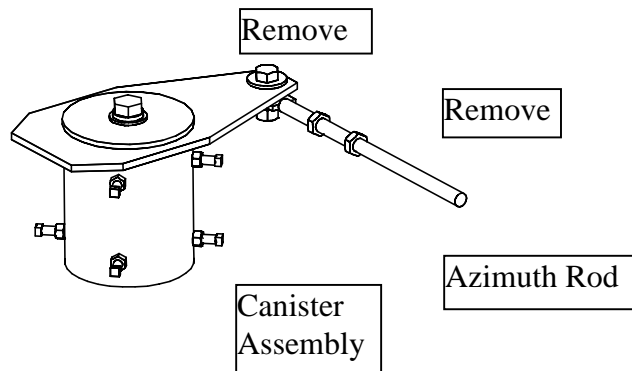

STEP 3:

- A). Remove rotation bolt, washer & lock washer and set aside.
- B). Remove [1] 1 / 2" jam nut.

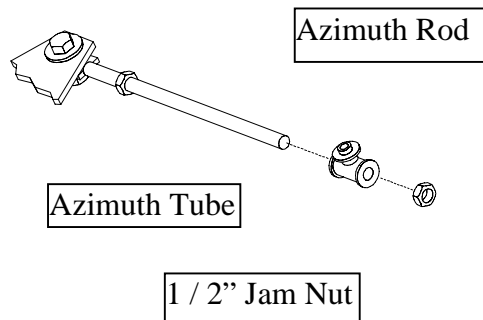

STEP 4:

- A). Slide azimuth tube (from Step. 1) onto azimuth rod.
- B). Replace 1 / 2" jam nut (from Step. 3) back onto azimuth rod.

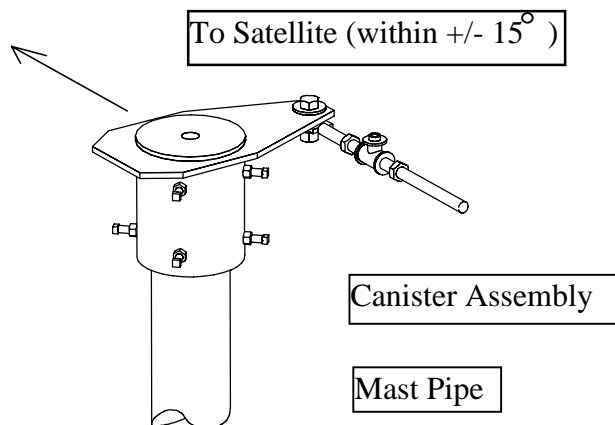

STEP 5:

- A). Place the canister assembly onto mast pipe.
- B). Orient the canister assembly approximately towards the center of the satellite orbital arc to within +/- 15°.
- C). Securely tighten [8] canister screws.
- D). Tighten [8] lock nuts against canister.

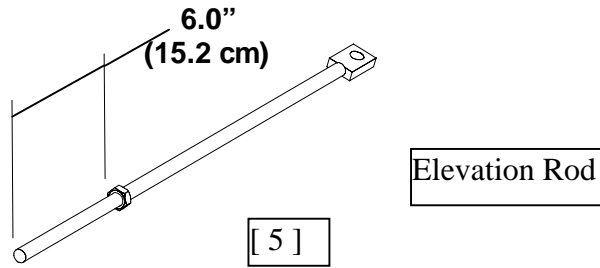

STEP 6:

- A). Thread 1 / 2" nut (item 5) approximately 6" (15.2 cm) onto elevation rod.

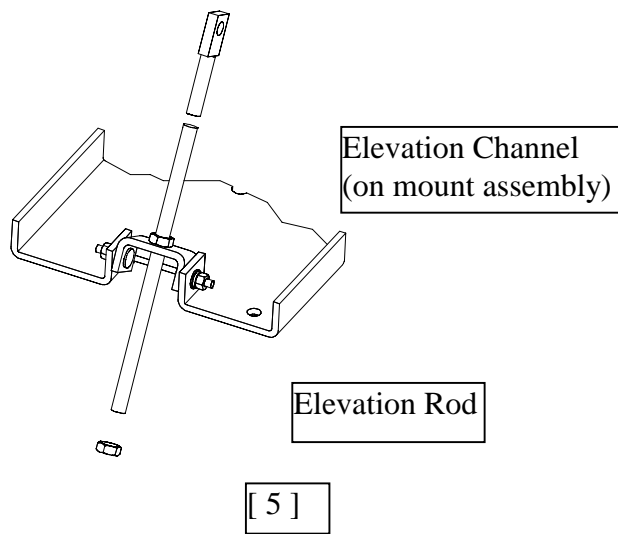

STEP 7:

- A). Insert elevation rod thru hole in elevation channel on mount assembly.
- B). Thread 1 / 2" nut (item 5) onto elevation rod.

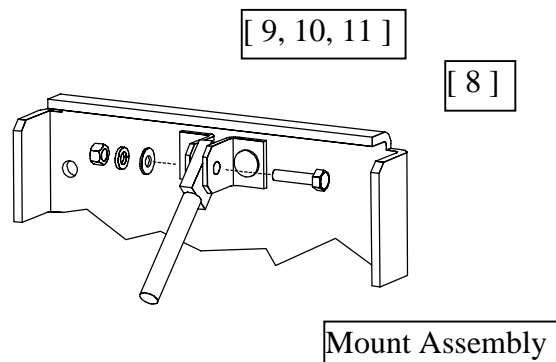

STEP 8:

- A). Attach elevation rod to the brackets on the back of the mount assembly with 5 / 16" hardware (items: 8, 9, 10, 11).
- B). Lightly tighten all hardware on the mount assembly at this time.

STEP 9:

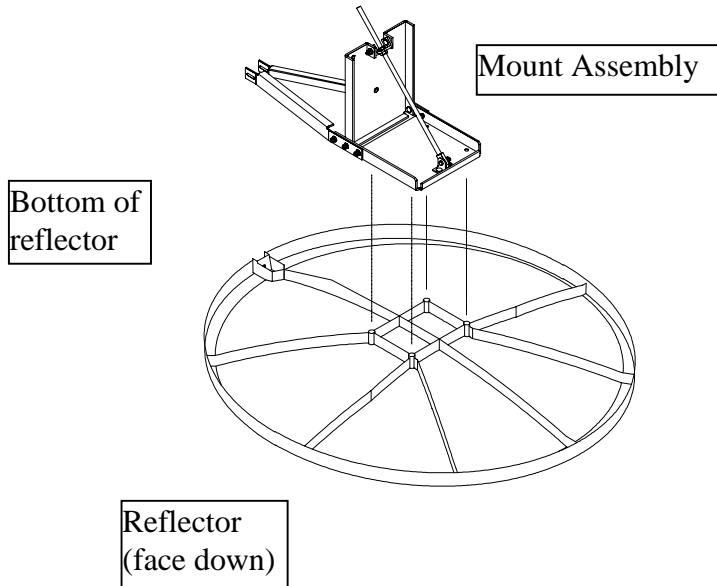

- A). Place the 1.2 meter reflector face down on a flat surface.
- B). Place the mount assembly onto the back of the reflector and orient as shown.
- C). Attach the mount assembly to the reflector with [4] HiLo screws (item 6).
- D). Tighten securely but **DO NOT** over tighten as this may cause damage to the reflector.

STEP 10:

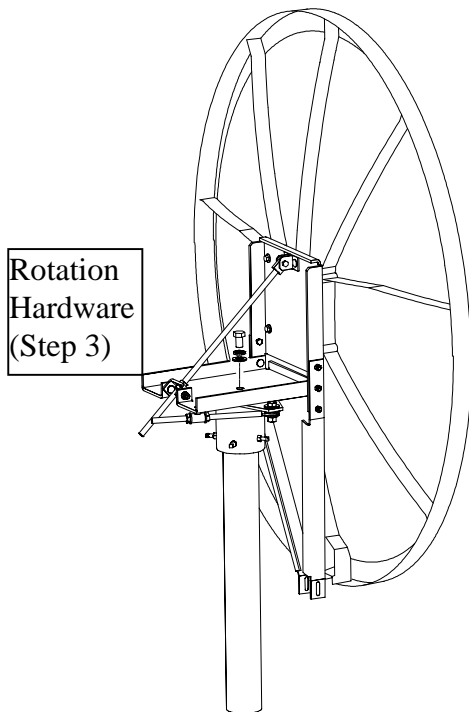

- A). Place the reflector mount assembly (Step. 9) onto the canister assembly.
- B). Secure reflector mount assembly with rotation bolt, washer & lock washer from Step 3.

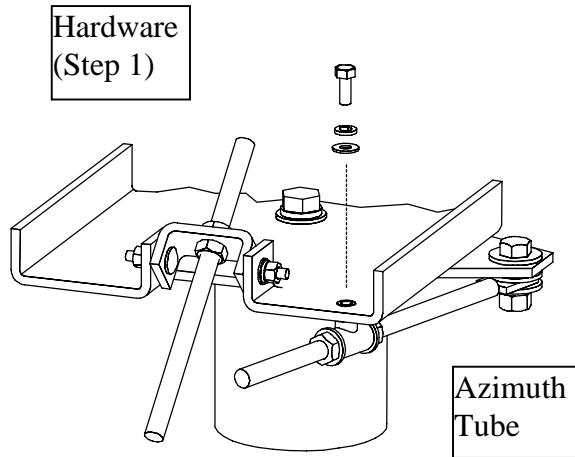
**STEP 11:**

- A). Adjust azimuth tube so that the tube will fit into the hole on the reflector mount assembly.
- B). Secure azimuth tube to the mount assembly with hardware set aside in Step 1.
- C). Tighten all hardware at this time.
- D). Follow instructions in Section II - 2.1 to install the feed supports.

2.1 FEED SUPPORT ASSEMBLY

These instructions are intended as a general reference for feed support assembly. If your antenna system has specific feed support installation instructions, then refer to them at this time.

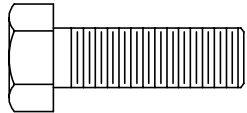
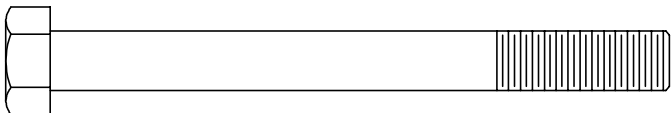
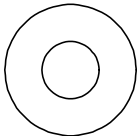
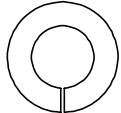
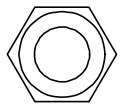
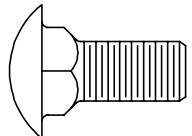
PARTS LIST - 1.2M FEED SUPPORT			
ITEM NO.	PART NO.	DESCRIPTION	QTY
1	VARIES	Feed Rod	2
2	VARIES	Feed Support Tube	1
3	8031-008	5 / 16" x 1.00" Bolt 	3
4	8031-026	5 / 16" x 3.25" Bolt 	1
5	8201-041	5 / 16" Flatwasher 	10
6	8202-041	5 / 16" Lock Washer 	6
7	8101-009	5 / 16" Hex Nut 	6
8	8038-006	5 / 16" x .75" Carriage Bolt 	2

CAUTION: During the assembly procedure, the sequence of instructions must be followed. **Do Not Tighten Any Hardware Until Instructed.** Refer to the feed support parts list and the steps shown below.

STEP 1:

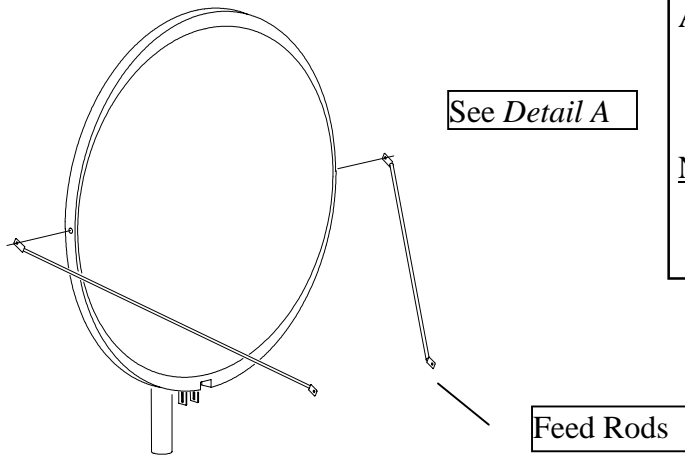

A). Attach feed rods to reflector with (items: 3, 6, 7) and with [2] of (item 5).

NOTE: The 2.00” flat end of the feed mounts to the outside rim of the reflector

STEP 2:

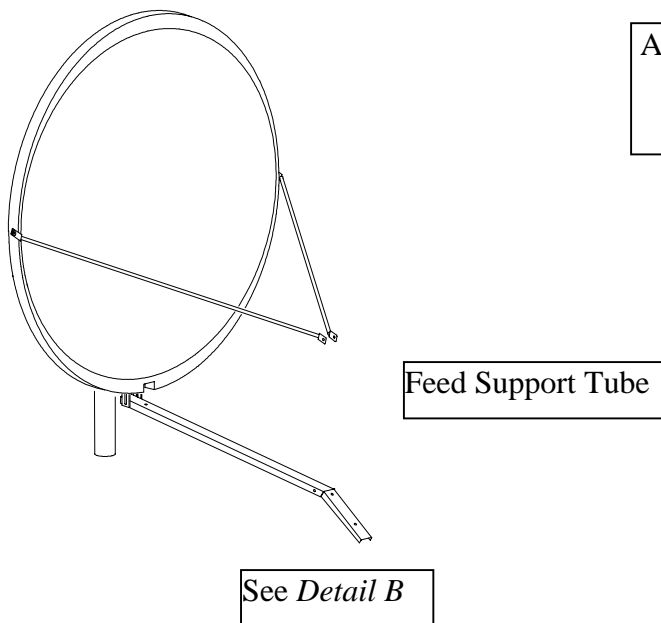

A). Mount feed support tube between the feed support brackets with [2] of (items: 8, 5, 6, 7).

STEP 3:

STEP 3:

- A). Connect the feed rods to the feed support tube with (items: 4, 6, 7) and with [2] of (item 5).

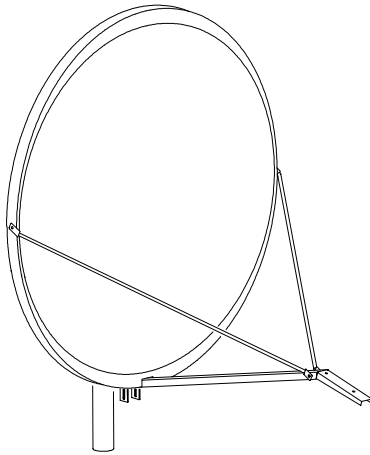

Feed Rod

See Detail C

Feed Support Tube

STEP 4:

- A). Attach feed support tube to the reflector with (items: 3, 6, 7) and with [2] of (item 5).
- B). Tighten the hardware at the reflector rim snugly (Detail A).
- C). Tighten the hardware connecting the feed rods to the feed support tube (Detail C).
- D). Tighten the hardware that connects the feed support tube to the feed support brackets (Detail B).
- E). Tighten the hardware connecting the feed support tube to the reflector (Detail D).
- F). Refer to separate instructions for the specific feed/ODU assembly to feed support.

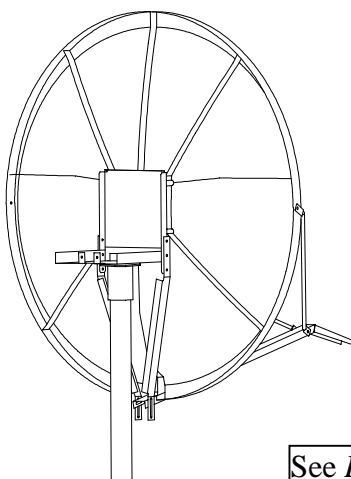

Feed Support Tube

See Detail D

DETAIL A

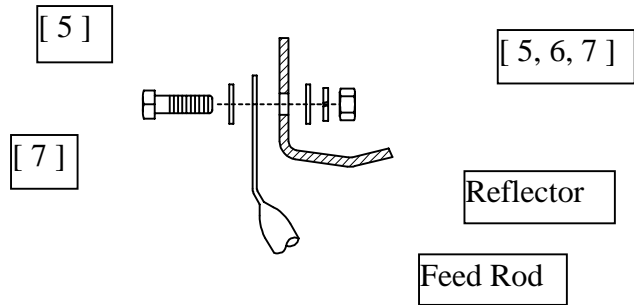

DETAIL B

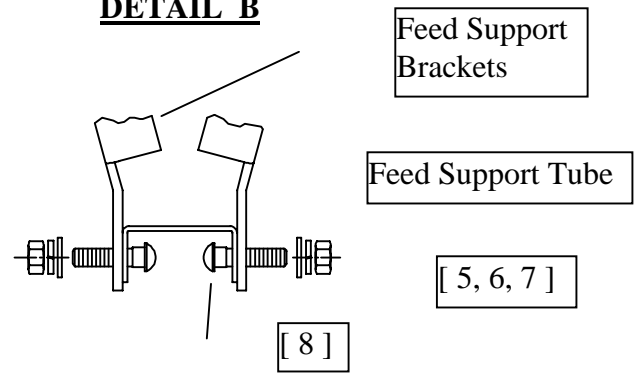

DETAIL C

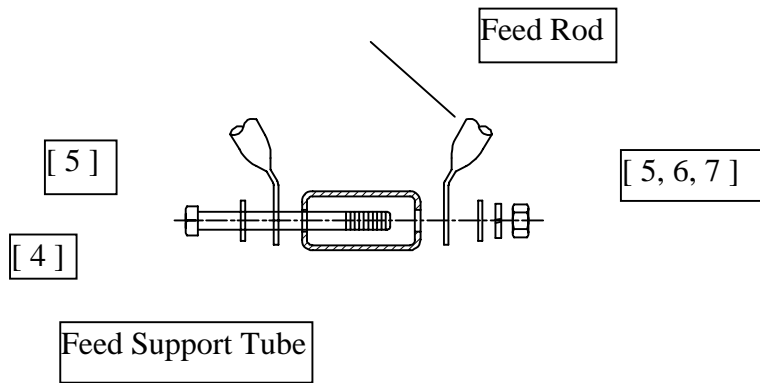

DETAIL D

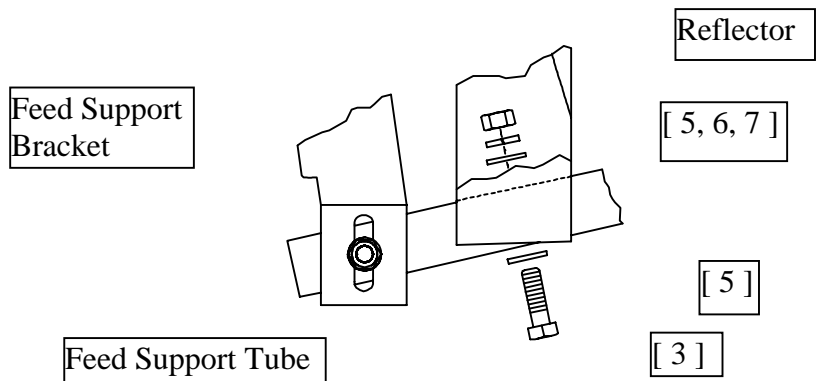

SECTION III ANTENNA POINTING

3.0 ANTENNA POINTING

The 1.2 meter reflector contains a 17.3° elevation offset look angle. Therefore, when the reflector aperture is perpendicular to the ground, the antenna is actually looking 17.3° in elevation. Refer to Figure 2.

- Step 1:** Place an inclinometer on the reflector support angle as shown in Figure 2.
- Step 2:** Adjust the reflector up or down in elevation by turning the two ½" hex nuts at the elevation channel until the desired elevation is read on the (inclinometer reading plus 17.3° = elevation angle). Note: Be sure that the elevation pivot hardware is loose enough to allow adjustment without damaging (bending) the elevation rod. Snug the hardware.
- Step 3:** Azimuth Adjustment: With the electronics set to acquire the satellite, rotate the antenna in azimuth until the satellite is found. Snug the azimuth adjustment hardware.
- Step 4:** Peak the antenna signal by fine adjustments made in both azimuth and elevation until the optimum signal is achieved.
- Step 5:** Tighten all hardware used for adjustment.

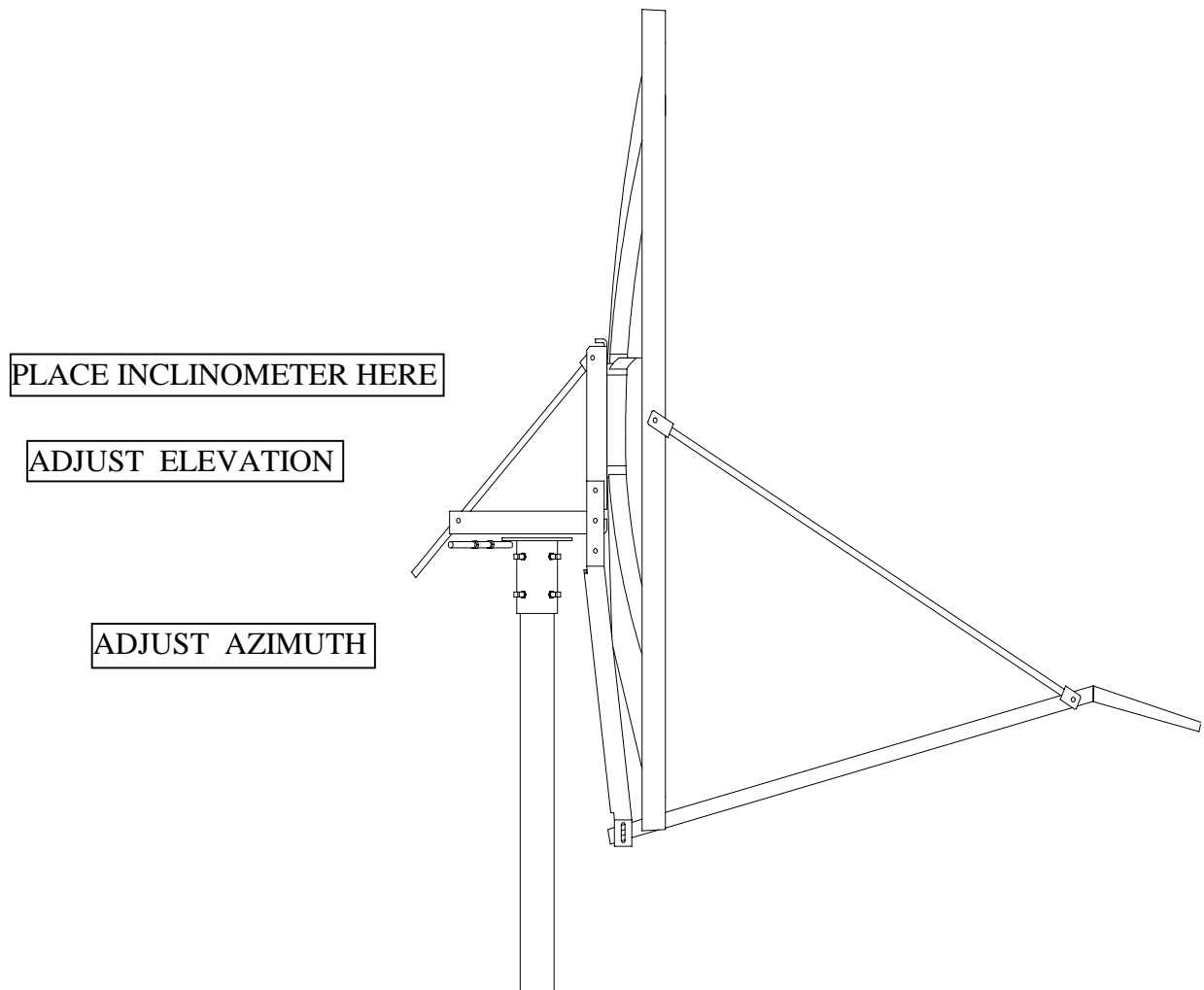

Figure 2

SECTION IV MAINTENANCE

4.0 MAINTENANCE OVERVIEW

After installation, the antenna requires only periodic inspection. It is anticipated that maintenance, if required, will be minimal and easily handled by a local or in-house maintenance staff.

4.1 REFLECTOR

Prodelin's reflector does not require any maintenance. The composite construction of the reflector is virtually impervious to any damages that could be caused by weather or atmospheric conditions.

It is only necessary to inspect for any physical damage done by vandalism or very severe weather conditions.

Should any damage be detected to a portion of the reflector, contact the Customer Service Department at Prodelin for recommendations involving reflector repair.

4.2 MOUNT AND REFLECTOR SUPPORT STRUCTURE

The mount and reflector support structure supplied with this antenna is of steel construction and has a galvanized finish.

If there are any signs of structural failure, the mount members that are damaged should be repaired or replaced.

CORROSION: Any corrosion on steel members may be repaired with a cold, zinc-rich galvanizing paint.

Note: Rust on the edges of stamped metal parts is normal and will not adversely affect the structural integrity of the antenna system.

4.3 FEED AND FEED SUPPORT

The feed support and feed rods should be inspected to insure that all hardware is secure. The feed/radio mounting bolts should be tight.

The feed horn window should be inspected to insure that it is intact so that no moisture can collect inside the feed horn.

Prodelin Corporation
Box contents for 1134 series, 1.2M .8 F/D, basic antenna
(Options to basic antenna not listed)

<u>Qty</u>	<u>P/N</u>	<u>Description</u>
1	0800-1366	1.2M .8 F/D Az/EL mount
1	0181-584	assy, reflector support, 1.2M, .8 F/D
1	0181-585	assy, canister, 1.2M, .8 F/D
1	0490-203	weldment, elevation rod, 1.2M, .8 F/D
1	4096-393	instructions, 1.2M .8 F/D Az/EL series 1134
2	0200-320	kit, hardware, 1.2M Az/EL mount
4*	8319-006	screw, 27/64 - 13 x 1 3/8", HL THD CTG
1*	8031-012	bolt, HHCS, 5/16-18 x 1.50", zinc w/ ultraguard
4*	8201-041	flatwasher, 5/16, zinc w/ ultraguard
3*	8202-041	lock washer, 5/16, zinc w/ ultraguard
3*	8101-009	nut, HEX, 5/16-18, zinc w/ ultraguard
2*	8104-007	nut, HEX, 1 / 2-13, zinc w/ ultraguard
2*	8031-008	bolt, HHCS, 5/16-18 x 1.00", zinc w/ ultraguard
1	0800-1362	1.2M Rx/Tx reflector w/ Ku feed, .8 F/D
1	0179-355	reflector, 1.2M offset, Rx/Tx, .8F/D
1	0800-1375	39 degree Ku band feed horn
1	0183-478	assy, 39 degree Ku band feed horn
1	4090-004	label, feed horn warning
1	0200-604	kit, hardware (includes the following):
1	0198-120	O ring, .962" I.D. x .067"
1	0268-003	allen wrench, 7/64" short arm
1	0432-036	grease silicon #3 pill
7	8200-010	lock washer, #6, internal tooth, stainless steel
7	8300-002	screw, SH, #6-32 x .50, stainless steel

* Quantity per 0200-320, total count is twice the number indicated