

C-band 5W Block Upconverter

MODEL NO. NJT5669 / 69F

XC-band 5W Block Upconverter

MODEL NO. NJT5670 / 70F



<Features>

- * Small Size & Light Weight
- * High Efficiency Output Power
(5 W minimum @P1dB over temperature)
- * Low Power Consumption
- * RoHS Compliance

<Line-Up>

Model No.	RF Frequency	Local Frequency	IF Frequency	Output Power	Connector
NJT5669	5.850 to 6.425 GHz	4.90 GHz	950 to 1,525 MHz	5W Linear (+37 dBm min.)	N-Type
NJT5669F					F-Type
NJT5670	6.725 to 7.025 GHz	5.76 GHz	965 to 1,265 MHz		N-Type
NJT5670F					F-Type

<Specifications>

Item	Specifications
Output Interface	CPR 137-G (Grooved) with Flange
Output Power @ P1 dB	+37.0 dBm minimum over temperature
Conversion Gain	58 dB nom.
Phase Noise (SSB)	-60 dBc/Hz max. @ 100Hz -70 dBc/Hz max. @ 1kHz -80 dBc/Hz max. @ 10kHz -90 dBc/Hz max. @ 100kHz
Input Interface	N-type, female (50 ohm) [Model No. NJT5669 / NJT5670] F-type, female (75 ohm) [Model No. NJT5669F / NJT5670F]
Required External Reference Signal	Frequency : 10 MHz Input Power: -5 to +5 dBm Phase Noise: -135 dBc/Hz @ 100Hz -140 dBc/Hz @ 1kHz -143 dBc/Hz @ 10kHz -143 dBc/Hz @ 100kHz
Mute	Shut off the HPA in case of LO unlocked
Input / Output V.S.W.R.	2.0:1 max. @ Input 2.0:1 max. @ Output
Power Requirement	+15 to +30 V dc
Power Consumption	55 W max.
Operating Temperature	-40 to +55 degrees C
Storage Temperature	-40 to +75 degrees C
Size & Weight	190.6 mm (L) x 167.1 mm (W) x 59 mm (H), 2.54 kg max. [7.50" (L) x 6.58" (W) x 2.32" (H)] [5.6 lbs]

<Outline Drawing>

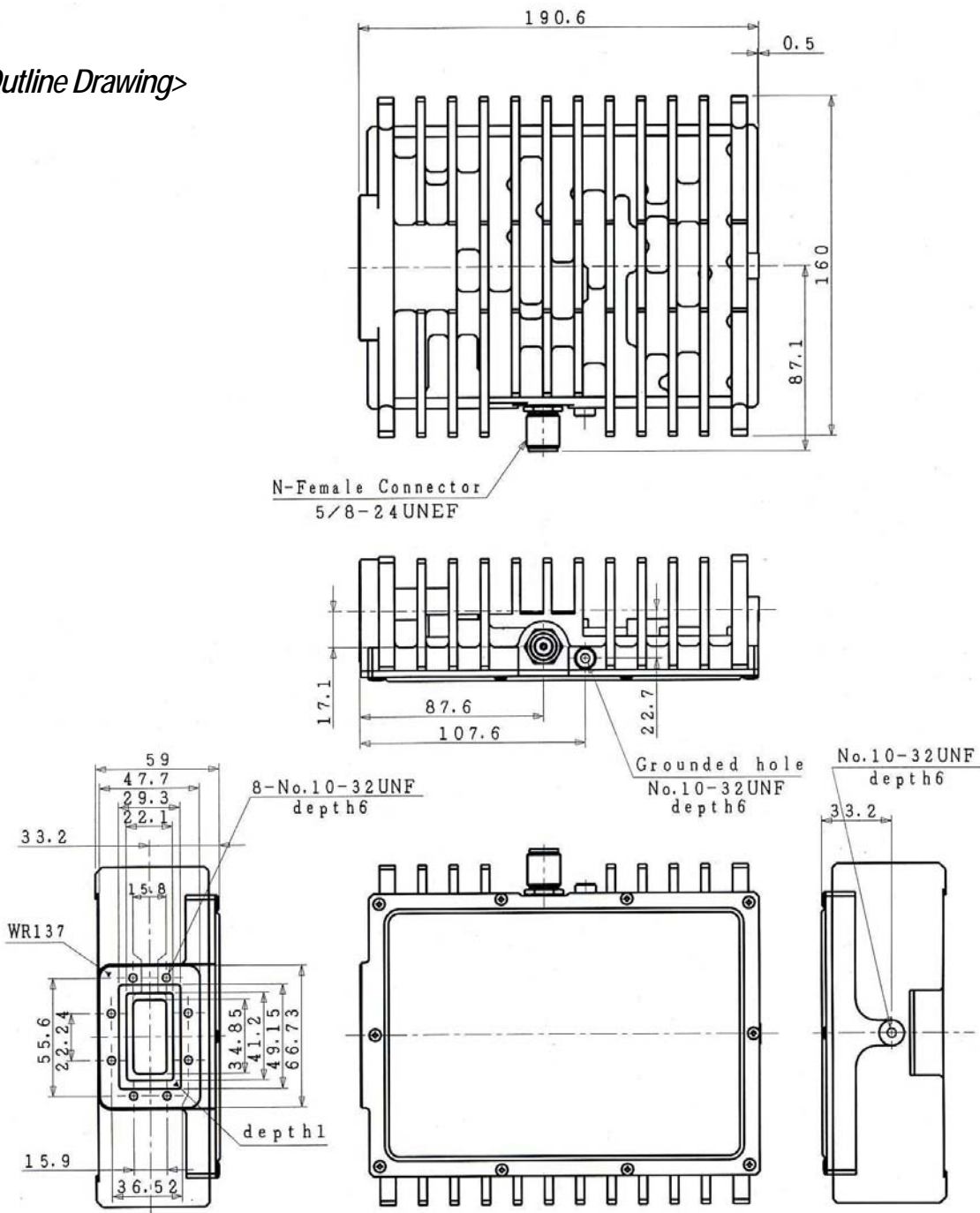

Unit : mm

JRC *New Japan Radio Co., Ltd.*

Satcom Resources

Post Office Box 1639
 101 Eagle Road - Building #7
 Avon, Colorado 81620 USA
 970 748-3094 or tollfree 866 SATCOM1
 Fax 970 748-3096
 www.satcomresources.com