



125W Ku-Band Compact Outdoor SSPA

## Description

The Paradise Datacom Compact Outdoor Solid State Power Amplifier (SSPA) is built for extreme environmental conditions and high reliability operation. Along with the robust construction exists the highest power density in the industry. This allows solid state technology to be used in applications that have long been reserved for TWTAs.

At less than 40 lbs. (18 kg), and only slightly larger than a shoe box, this family of SSPAs is available in output power levels in the following range:

**S-Band: 50W - 300W**

**C-Band: 50W - 300W**

**X-Band: 60W - 250W**

**Ku-Band: 25W - 125W**



Antenna-mount 1:1 system w/ mounting frame



SNG-mount 1:1 system w/ side-mount AC input

## FEATURES

- Compact size and weight
- CE Compliance Tested
- Integrated forced-air cooling system
- Adjustable RF Gain, 55 dB to 75 dB
- Extreme Environmental Testing
- RF Output Sample Port
- Maintenance Free Operation
- Universal, Power Factor Corrected Power Supply
- Built-in 1:1 Redundancy Control

## OPTIONS

- Antenna Mounting Kit
- DC Operation (48VDC)
- Remote Control Panel
- L-Band Input
- FSK monitor & control via IFL
- Phase Combined Systems
- Wireless local interface - Bluetooth™ enabled
- Low line voltage operation
- Fiber Optic Input
- Optional side-mount AC input for SNG installations
- L-Band Bypass Switch for L-Band or RF input

## SPECIFICATIONS

- Compact Outdoor housing  
10.0 X 19.5 X 6.50 in  
254 X 495 X 165 mm  
36.0 lbs. / 16.4 kg;  
44.0 lbs. / 20.0 kg for higher powered units
- White powder coat finish
- Operating temperature:  
-40 to +60 °C



# Compact Outdoor Solid State Power Amplifiers in S-, C-, X-, and Ku-Bands

## Specifications, S-Band SSPAs

PARAMETER	NOTES	LIMITS	UNITS
Frequency Range	A Series Sub-band B Series Sub-band	2.020 to 2.120 2.200 to 2.300	GHz GHz
Output Power @: Saturation/ $P_{1dB}$ (Typical/Guaranteed minimum)	<b>A Series</b> HPAS2050ACXXXXX (2.020 - 2.120 GHz) HPAS2100ACXXXXX (2.020 - 2.120 GHz) HPAS2200ACXXXXX (2.020 - 2.090 GHz) HPAS2200ACXXXXX (2.095 - 2.120 GHz) HPAS2300ACXXXXX (2.020 - 2.090 GHz) HPAS2300ACXXXXX (2.095 - 2.120 GHz) <b>B Series</b> HPAS2050BCXXXXX (2.200 - 2.300 GHz) HPAS2100BCXXXXX (2.200 - 2.300 GHz) HPAS2200BCXXXXX (2.200 - 2.300 GHz) HPAS2300BCXXXXX (2.200 - 2.300 GHz)	$P_{sat} / P_{1dB}$ 47.5/47.0 (56/50) 50.5/50.0 (112/100) 53.5/53.0 (223/200) 53.0/52.5 (200/178) 55.0/54.5 (316/280) 54.4/54.0 (280/250) 47.5/47.0 (56/50) 50.5/50.0 (112/100) 53.5/53.0 (223/200) 55.0/54.5 (316/280)	dBm (W) dBm (W) dBm (W) dBm (W) dBm (W) dBm (W) dBm (W) dBm (W) dBm (W) dBm (W)
Power Requirements Line Voltage Line Frequency Line Power	power factor corrected  HPAS2050ACXXXXX HPAS2100ACXXXXX HPAS2200ACXXXXX HPAS2300ACXXXXX	90 to 265 47 to 63 425 650 1000 (180 - 265 VAC only) 1600 (180 - 265 VAC only)	VAC Hz W W W W
Receive Band Reject Filter External filter for sub-band A SSPAs only	Insertion Loss Rx Reject @ 2.200 GHz	- 0.3 - 60	dB dB
Receive Band Noise Power Density For sub-band A SSPAs only	Without optional filter With optional filter	-95 -155	dBW/4 KHz dBW/4 KHz

## Specifications, C-Band SSPAs

PARAMETER	NOTES	LIMITS	UNITS
Frequency Range	(see options for extended band)	5.850 to 6.425	GHz
Output Power @: Saturation/ $P_{1dB}$ (Typical/Guaranteed minimum)	HPAC2030ACXXXXX HPAC2040ACXXXXX HPAC2050ACXXXXX HPAC2075ACXXXXX HPAC2100ACXXXXX HPAC2140ACXXXXX HPAC2200ACXXXXX HPAC2250ACXXXXX HPAC2300ACXXXXX	$P_{sat} / P_{1dB}$ 45.0/44.8 (32/30) 46.0/45.8 (40/38) 47.0/46.8 (50/48) 48.8/48.5 (76/70) 50.0/49.5 (100/89) 51.5/51.0 (141/126) 53.0/52.3 (200/170) 54.0/53.0 (250/200) 54.7/54.0 (300/251)	dBm (W) dBm (W) dBm (W) dBm (W) dBm (W) dBm (W) dBm (W) dBm (W) dBm (W) dBm (W)
Power Requirements Line Voltage Line Frequency Line Power	power factor corrected  HPAC2030ACXXXXX HPAC2040ACXXXXX HPAC2050ACXXXXX HPAC2075ACXXXXX HPAC2100ACXXXXX HPAC2140ACXXXXX HPAC2200ACXXXXX HPAC2250ACXXXXX HPAC2300ACXXXXX	90 to 265 47 to 63 300 350 400 450 700 850 (180 - 265 VAC)* 1000 (180 - 265 VAC)* 1300 (180 - 265 VAC)* 1700 (180 - 265 VAC)* *90-265 VAC option available	VAC Hz W W W W W W W W W

## Specifications, X-Band SSPAs

PARAMETER	NOTES	LIMITS	UNITS
Frequency Range	(see options for extended band)	7.900 to 8.400	GHz
Output Power @: Saturation/ $P_{1dB}$ (Typical/Guaranteed minimum)	HPAX2060ACXXXXX HPAX2075ACXXXXX HPAX2100ACXXXXX HPAX2140ACXXXXX HPAX2200ACXXXXX HPAX2250ACXXXXX	$P_{sat} / P_{1dB}$ 47.5 / 47.3 (60 / 54) 48.8 / 48.3 (76 / 68) 50.0 / 49.5 (100 / 89) 51.4 / 50.8 (140 / 120) 53.0 / 51.8 (200 / 170) 54.0 / 53.0 (250 / 200)	dBm (W) dBm (W) dBm (W) dBm (W) dBm (W) dBm (W)
Power Requirements Line Voltage Line Frequency Line Power	power factor corrected  HPAX2060ACXXXXX HPAX2075ACXXXXX HPAX2100ACXXXXX HPAX2140ACXXXXX HPAX2200ACXXXXX HPAX2250ACXXXXX	90 to 265 47 to 63 650 700 750 1225 (180-265 VAC only)* 1370 (180-265 VAC only)* 1550 (180-265 VAC only)* *90-265 VAC option available	VAC Hz W W W W W W

## Specifications, Ku-Band SSPAs

PARAMETER	NOTES	LIMITS	UNITS
Frequency Range	(see options for extended band)	14.00 to 14.50	GHz
Output Power @: Saturation/ $P_{1dB}$ (Typical/Guaranteed minimum)	HAK2010ACXXXXX HAK2020ACXXXXX HAK2025ACXXXXX HAK2035ACXXXXX HAK2040ACXXXXX HAK2050ACXXXXX HAK2070ACXXXXX HAK2100ACXXXXX HAK2125ACXXXXX	$P_{sat} / P_{1dB}$ 40.0/39.0 (10/8) 43.0/42.0 (20/16) 44.0/43.0 (25/20) 45.5/44.5 (35/28) 46.0/45.0 (40/31) 47.0/46.0 (50/40) 48.5/47.5 (70/56) 50.0/49.0 (100/80) 51.0/50.0 (125/100)	dBm (W) dBm (W) dBm (W) dBm (W) dBm (W) dBm (W) dBm (W) dBm (W) dBm (W)
Power Requirements Line Voltage Line Frequency Line Power	power factor Line voltage Line frequency HAK2010ACXXXXX HAK2020ACXXXXX HAK2025ACXXXXX HAK2035ACXXXXX HAK2040ACXXXXX HAK2050ACXXXXX HAK2070ACXXXXX HAK2100ACXXXXX HAK2125ACXXXXX	.98 90 to 265 47 to 63 220 250 320 350 550 600 650 1000 (180-265 VAC)* 1150 (180-265 VAC)* *90-265 VAC option available	VAC Hz W W W W W W W W W

## Common Electrical Specifications

PARAMETER	NOTES	LIMITS	UNITS
Gain	range	55-75	dB
Gain Flatness	full band (C-,X-,Ku-bands)	±1.0	dB
	full band (S-band)	±0.5	dB
Gain Slope	per 40 MHz (C-,X-,Ku-bands)	±0.3	dB/40 MHz
	Per 40 MHz (S-band)	±0.1	dB/40 MHz
Gain Variation vs. Temperature	-40°C to +60°C	±1.5	dB
Gain Adjustment	0.1 dB resolution	20	dB
Intermodulation Distortion	Two-Tone 3 dB back off from P <sub>1dB</sub>	-25	dBc
AM/PM Conversion	@ rated P <sub>1dB</sub>	3.5	°/dB
	@ P <sub>1dB</sub> - 1 dB	1.5	°/dB
	@ P <sub>1dB</sub> - 2 dB	1.0	°/dB
Spurious Harmonics (SSPA only)	(@ rated P <sub>1dB</sub> ) (@ rated P <sub>1dB,3dB</sub> ) (C-,X-,Ku-bands) (@ rated P <sub>1dB,3dB</sub> ) (S-band)	-60 -50 -30	dBc dBc dBc
Input/Output VSWR		1.3:1	
Noise Figure	at maximum gain (C-,X-,Ku-bands) at maximum gain (S-band)	10 8	dB dB
Group Delay (per 40 MHz segment)	Linear Parabolic Ripple	0.01 0.003 1.0	ns/MHz ns/MHz <sup>2</sup> ns p-p
Transmit Band Noise Output Power Density	TX Band RX Band (C-,X-,Ku-bands) RX Band (S-band)	-75 -150 See options	dBW/4 KHz dBW/4 KHz
Receive Band Noise Output Power Density	S-Band, with optional filter S-Band, without optional filter	-155 -95	dBW/4 KHz dBW/4 KHz
Residual AM Noise	0 - 10 KHz 10 KHz - 500 KHz 500 KHz - 1 MHz	-45 -20 (1.25 + log F) -80	dBc dBc dBc
Phase Noise (SSPA only)	Offset frequency from carrier 10 Hz 100 Hz 1 KHz 10 KHz 100 KHz 1 MHz	-90 -100 -110 -120 -125 -130	dBc/Hz dBc/Hz dBc/Hz dBc/Hz dBc/Hz dBc/Hz
RF Power Detector	P <sub>sat</sub> to (P <sub>sat</sub> -20 dBm)	20 ± 1.0	dBm

Specifications are subject to change.

## L-Band Operation

Paradise Datacom offers C-, X-, and Ku-Band amplifiers with an integrated L-Band Block Up Converter. The L-Band units utilize Paradise Datacom's proprietary ZBUC™ technology. The addition of a ZBUC™ to a Compact Outdoor SSPA typically increases the gain by 2-5 dB. The advantages of ZBUC technology include:

- ZBUC can detect and switch to an externally supplied reference.
- Optional Internal high stability (10MHz) reference.
- ZBUC can lock to an externally supplied reference of 5, 10, 20, 25, or 50 MHz without modification.
- ZBUC can accept a wide range of external reference power (-15dBm to +5 dBm)
- ZBUC can accept FSK monitor and control signal via the IFL for complete amplifier remote control.

## Available Frequency Plans

Band	Frequency Band	IF Input	LO Frequency	RF Output
C	Standard C-Band	950 - 1525 MHz	4.900 GHz	5.850 - 6.425 GHz
C	Extended C-Band	950 - 1825 MHz	4.900 GHz	5.850 - 6.725 GHz
C	Palapa Band	950 - 1250 MHz	5.475 GHz	6.425 - 6.725 GHz
C	Insat Band	950 - 1250 MHz	5.775 GHz	6.725 - 7.025 GHz
X	Standard X-Band	950 - 1450 MHz	6.950 GHz	7.900 - 8.400 GHz
Ku	Standard Ku-Band	950 - 1450 MHz	13.050 GHz	14.00 - 14.50 GHz
Ku	Extended Ku-Band	950 - 1700 MHz	12.800 GHz	13.75 - 14.50 GHz

## Electrical Specifications for Compact Outdoor with ZBUC™

PARAMETER	NOTES	LIMITS				UNITS	
Gain	Nominal setting	75				dB	
Gain Flatness	full band (C-,X-,Ku-bands)	±2.0				dB	
Gain Slope	per 40 MHz (C-,X-,Ku-bands)	±0.4				dB/40 MHz	
Gain Adjusted Range		20				dB	
Gain Stability	Typical C-Band Adj. Range	60 - 80				dB	
	Typical Ku-Band Adj. Range	57 - 77				dB	
	-40 to +60 °C	±1.5				dB	
Phase Noise	Offset frequency from carrier	Absolute max.	C-band (typ.)	X-band (typ.)	Ku-band (typ.)		
	10 Hz	-30	-60	-60	-50	dBc/Hz	
	100 Hz	-60	-80	-75	-65	dBc/Hz	
	1 KHz	-70	-80	-75	-72	dBc/Hz	
	10 KHz	-80	-85	-100	-90	dBc/Hz	
	100 KHz	-90	-120	-110	-110	dBc/Hz	
	1 MHz	-90	-125	-122	-120	dBc/Hz	
Spurious	In-Band Signal Related (C-/Ku-Band)					-50	dBc
	(Extended C-Band)					-40	dBc
	Close to Carrier Spurious (≤ 20 MHz)					-50	dBc
	Local Oscillator					-30	dBm
	Non-Signal Related					-40	dBm
Noise Figure	At 75 dB gain setting					20	dB
Input VSWR	L-Band					1.5 : 1	
Internal Reference Option	10 MHz accuracy from -40 to +60 °C					±130	HZ

## Remote Control Panel - Ethernet Interface for the Compact Outdoor SSPA



The RCP2-1000 is a Remote Control Panel for the Compact Outdoor SSPA. It only requires 1RU of cabinet space and provides an identical local interface as exists on Paradise Datacom Indoor Rack Mount amplifiers.

The controller communicates with the outdoor amplifier via a RS485 link. The controller then provides a wide range of interface capability including Ethernet communications. The following communication links are available at the Remote Control Panel:

- RS232 or Addressable RS485 Serial Data
- Discrete (Parallel) Interface - Form C contact outputs & Opto Isolated Inputs
- Ethernet Interface - A full complement of Ethernet Communications including UDP, SNMP, and an internal web browser.
- Local (Manual) interface via front panel LCD display

## Fiber Optic Interface

Paradise Datacom offers an Outdoor Fiber Optic Converter Module (OFM-1000) for the Compact Outdoor SSPA which interfaces with a rack mountable Fiber Optic to L Band Transceiver (RCPF-1000).

The 1RU Indoor Fiber Optic to L Band Transceiver complements the Compact Outdoor Amplifier for a complete Optical interface for the amplifier.

What distinguishes the Paradise Datacom Fiber Optic solution is the ability to transmit and receive not only the L-Band IFL, but also a 10 MHz reference signal and an FSK signal that provides complete remote control of the amplifier. When equipped with a Paradise Datacom PD25 L-Band modem, a complete base-band to optical interface is realized.

A system utilizing a Fiber Optic link can have an IFL length in excess of 1km. An optical link is also desirable in areas in which L-Band interference can degrade the system's performance.



## Outline Drawing, Compact Outdoor SSPA (typical)

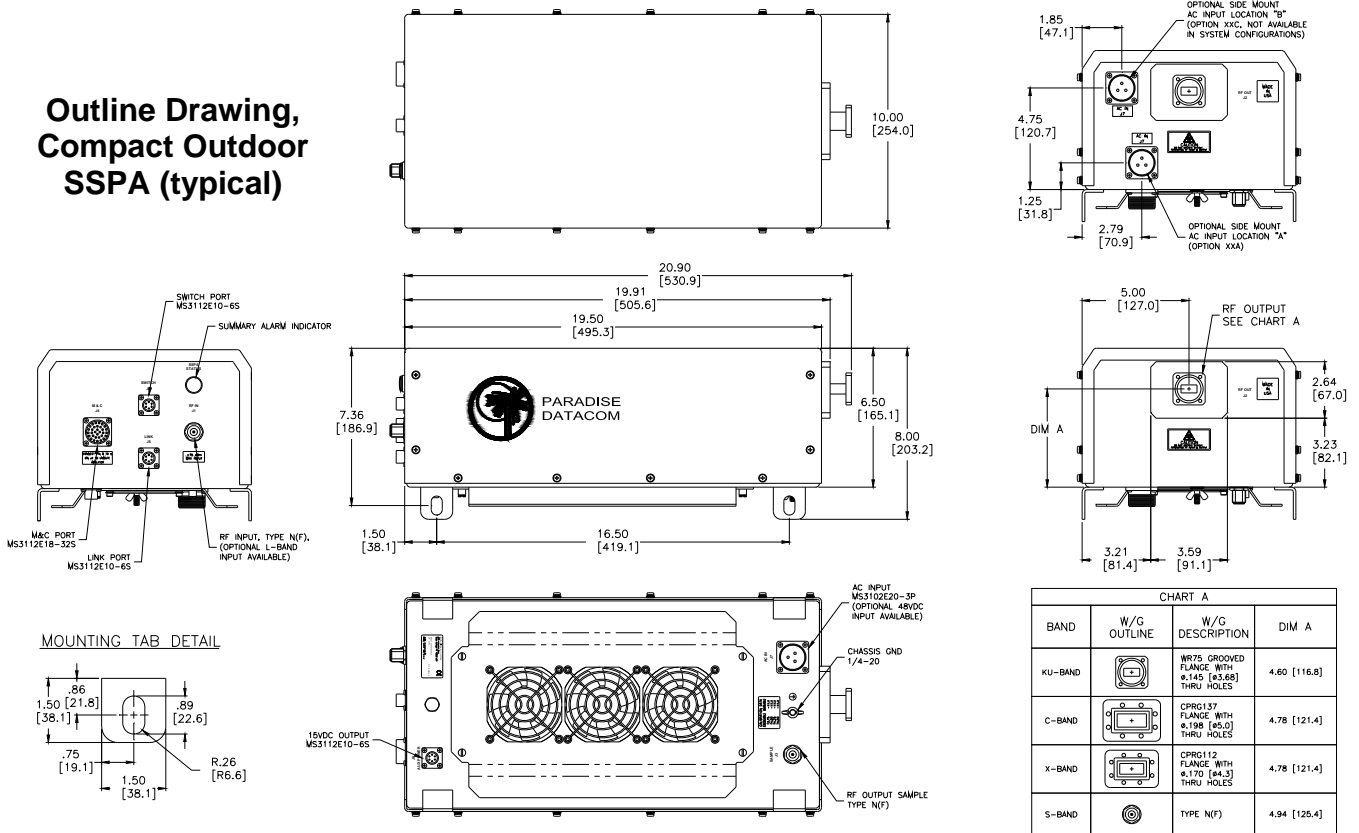

## Mechanical & Environmental Specifications

PARAMETER	NOTES	LIMITS	UNITS
Size	width X length X height	10.0 X 19.5 X 6.50 254 X 495 X 165	inches mm
Weight	S-/C-/X-Band to 200W / Ku-Band to 70W 250W C,X-Band / 100, 125 W Ku-Band	36 (16.4) 44 (20.0)	lbs.(kg) lbs.(kg)
Finish		Paint	White; powder coat
Connectors	RF Input RF Output HPAS2XXXACXXXXX HPAK2XXXACXXXXX HPAC2XXXACXXXXX HPAX2XXXACXXXXX RF Output Sample Line Power Monitor and Control Link Port Redundancy Switch Auxiliary +15VDC LNB Power (500 mA)	Type N  Type N WR75 Waveguide WR137 Waveguide WR112 Waveguide  Type N 3-pin MS-type 32-pin MS-type 6-pin MS type 6-pin MS-type 6-pin MS-type	Female  Female Grooved flange (PBR-120) CPR137G flange (PDR-70) CPR112G flange (PDR-84) Female Plug Socket Socket Socket
Operating Temperature	Ambient	-40 to +60	°C
Relative Humidity	Condensing	100	%
Cooling System	Integrated	Forced air	
Altitude	No temperature de-rating up to 10,000 ft, (3000 m) De-rate maximum temperature by 2°C per 1,000 ft (300 m) beyond 10,000 ft.		
Shock	50 g p-p, 11 msec pulses		
Vibration	3g rms 30 min. 5-2000 Hz		

## Part Number Configuration

HPA  2  C  X

**Band**  
S - S-Band  
C - C-Band  
X - X-Band  
K - Ku-Band

**Power Level (in Watts)**  
S-Band  
050, 100, 200 or 300  
C-Band  
030, 040, 050, 075, 100, 140,  
200, 250 or 300  
X-Band  
060, 075, 100, 140, 200, or 250  
Ku-Band  
010, 020, 025, 035, 040, 050,  
070, 100, or 125

**Frequency Sub Band**  
S-Band  
A - 2.020 - 2.120 GHz  
B - 2.200 - 2.300 GHz  
C-Band  
A\* - 5.85 - 6.425 GHz  
B\* - 5.85 - 6.725 GHz  
C - 5.75 - 6.670 GHz  
E\* - 6.425 - 6.725 GHz (Palapa)  
F\* - 6.725 - 7.025 GHz (Insat)  
X-Band  
A\* - 7.90 - 8.40 GHz  
B - 7.50 - 8.50 GHz  
D - 7.70 - 8.40 GHz  
E - 7.75 - 8.50 GHz  
Ku-Band  
A\* - 14.00 - 14.50 GHz  
B\* - 13.75 - 14.50 GHz  
C\* - 14.50 - 14.70 GHz  
D\* - 15.10 - 15.40 GHz  
  
\* Available with optional BUC

**Configuration Modifier**  
XXX = Standard  
KXX<sup>1</sup> = 110 VAC Option  
XMX = MS-Connector Covers  
XXA = Side-mount AC Input,  
Location 'A'  
XXC<sup>2</sup> = Side-mount AC Input,  
Location 'B'  
XXD = 48VDC Input  
XXF = Side-mount 48V Input,  
Location 'A'  
XXG<sup>2</sup> = Side-mount 48V Input,  
Location 'B'  
  
<sup>1</sup> Available in C- and X-Band models ≥140W  
and Ku-band models ≥100W.  
<sup>2</sup> Not available with System Configurations.

**System Configuration**  
X = Standalone  
  
Refer to the following specification sheets:  
• 203581 for Redundant Systems;  
• 203582 for Phase Combined Systems.

**Block Up Converter**  
B = BUC (Custom)  
M = Internal Reference ZBUC  
P = External Reference ZBUC  
R = Internal Reference ZBUC w/ Bypass Switch  
S = External Reference ZBUC w/ Bypass Switch  
X = None

**Package**  
C = Standard Compact Outdoor  
  
Refer to specification sheet 205489 for Fiber options.

**Example:** A standalone 70W Extended Ku-Band Compact Outdoor SSPA with an optional 48 VDC input and no block up converter is part number: **HPAK2070BCXXXD**.