

Application Brief – BUC Basics

A Block Upconverter or “BUC” is an outdoor unit used as part of a satellite terminal. A BUC converts the L-band Intermediate Frequency (carrying voice, data and/or video) to C or Ku-band satellite frequencies. Terrasat BUCs have integrated SSPAs (Solid State Power Amplifiers) and are available in a single package with output power levels up to 80W (C-band) and 40W (Ku-band).

Terrasat IBUCs are “Intelligent BUCs”. They have complete monitor and control facilities via FSK to the modem, RS32, RS485, and TCP/IP. When used with phase-locked Low Noise Block Converters (LNBs) with C or Ku-band input and L-band output, Terrasat BUCs offer a cost-effective alternative to traditional transceivers that operate with 70/140 MHz IF. Terrasat BUCs are compatible with L-band modems from all leading modem suppliers.

Terrasat’s IBUC includes a TCP/IP interface that serves M&C information and diagnostics on web pages. For small scale networks the web page interface can provide network management functionality, eliminating the need for a complex network management package.

BUCs receive the L-band signal as well as a 10 MHz reference signal and DC power from L-band modems. The combined signal is carried via a single coaxial cable to the BUC. For higher power BUCs (over 10W C or 8W Ku) L-band modems do not provide adequate DC power. Terrasat offers outdoor power supplies for BUCs with higher output power levels.

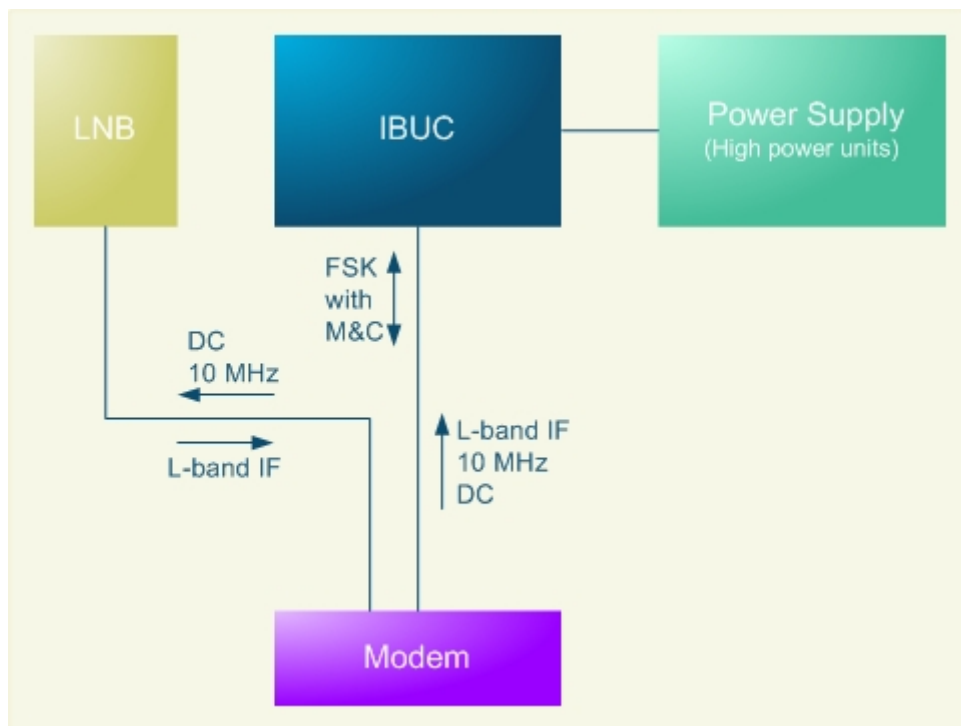

Typical Satcom Terminal